

**BENCH ASSEMBLY**

NOTE: SEAT PLANK SHOWN  
DOTTED FOR CLARITY

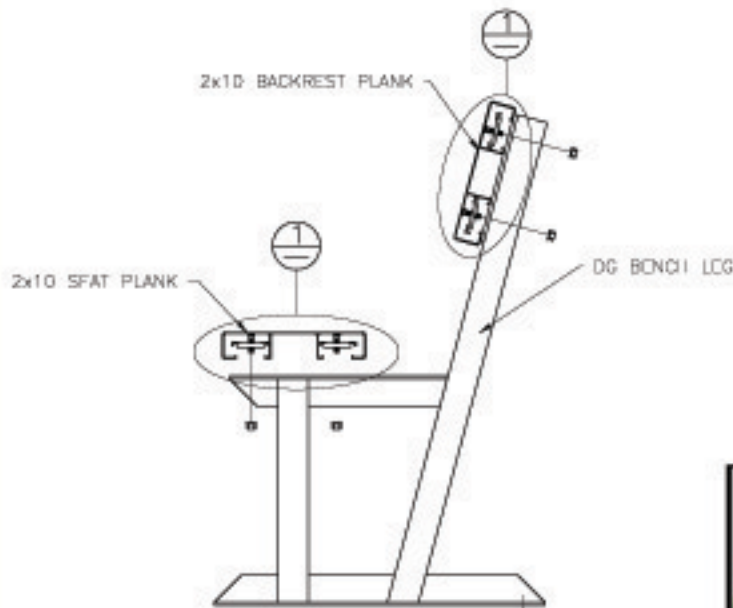
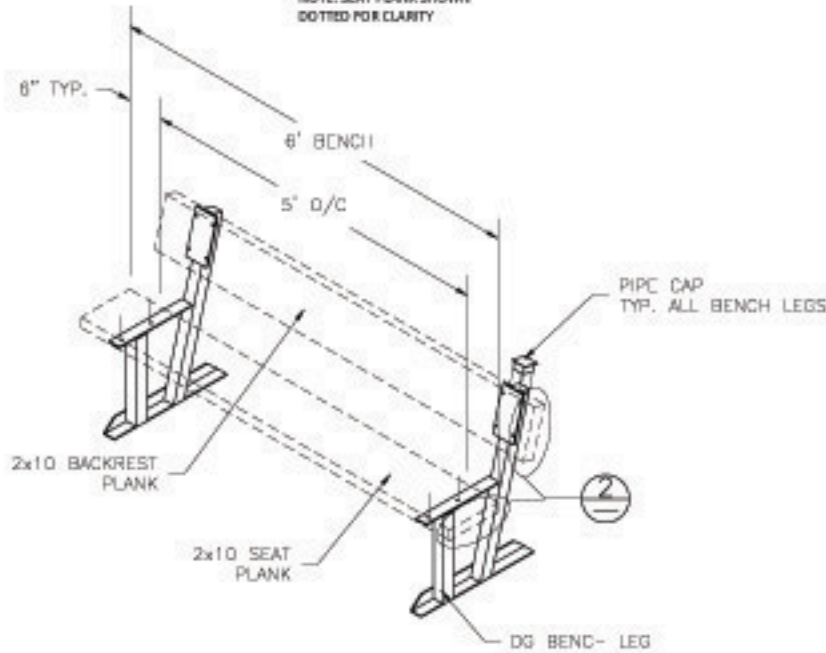

SEE DETAILS 3 & 4 FOR ANCHORING OPTIONS

**TYP 2x10 PLANK ATTACHMENT**

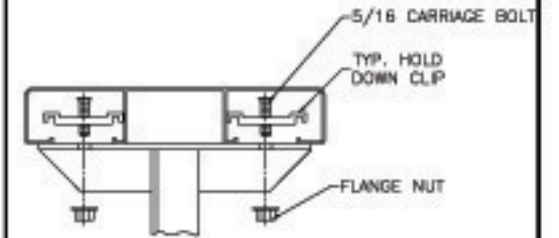

NOT TO SCALE

**TYP 2x10 ENDCAP ATTACHMENT**

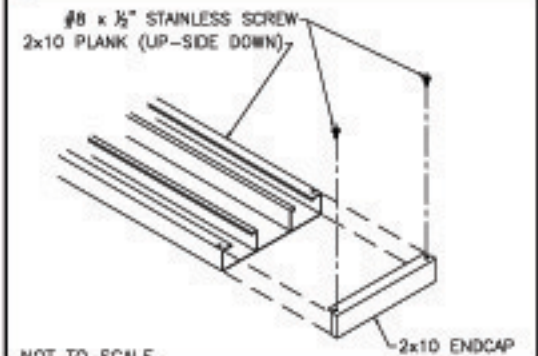

NOT TO SCALE

**TYP ANCHORING DETAIL**

ATTACH USING 3/8 x 2 3/4" CONCRETE ANCHOR, 1 1/2" MIN. EMBEDMENT.

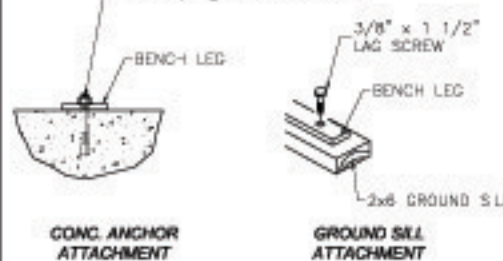

NOT TO SCALE

**RUBBER FOOT PAD ATTACH. DETAIL**

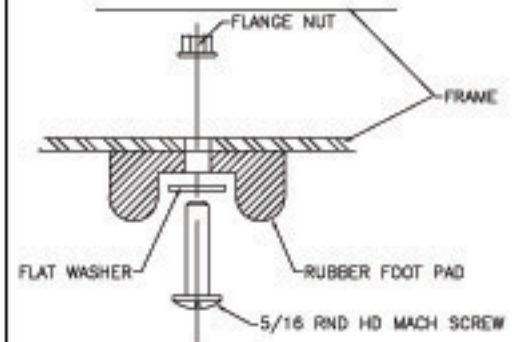

**builtriteBLEACHERS.com**  
67 Canterbury Ln Southington, CT 06489

SCALE: N.T.S.	APPROVED BY:	DRAWN BY: IMP
DATE: 6/4/12		
TITLE: DG BENCH DIMENSION LAYOUT		
CUSTOMER:		DRAWING NUMBER: BE-PI(DIM)