

DRAPER

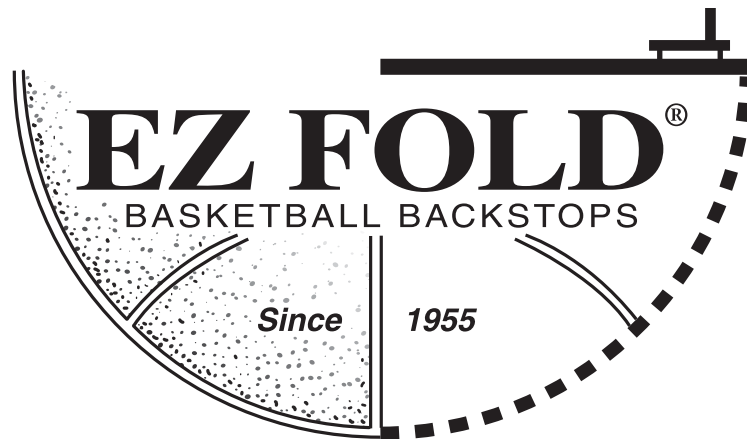

Installation Instructions Wall Mounted Basketball Backstops

DRAPER®

411 S. Pearl St., Spiceland, IN 47385 USA ■ 765-987-7999
www.draperinc.com ■ fax 765-987-7142

Copyright ©2010 Draper Inc. Form EZFold-Wall_Inst10 Printed in U.S.A.

If you encounter any difficulties installing or service your EZ-Fold® backstop, call your dealer or Draper, Inc., Spiceland, Ind., (765) 987-7999 or fax (765) 987-7142.

Caution

- ① When laying out parts, be careful not to place them where they may be in the way of scaffolding, lifts, or working areas.
- ② Before beginning assembly, locate and identify all parts using hardware list and project drawings.
- ③ Backstops must be installed level and plumb.
- ④ Make sure power is disconnected before wiring winches.
- ⑤ Do not install damaged or defective parts.
- ⑥ For warranty information, consult separate information sheet.
- ⑦ When calling Draper, Inc., with questions, please have your order number, and, if possible, project drawing that was provided with your backstop.
- ⑧ **Have architect/general contractor verify backstop and court line locations prior to beginning installation.**

These instructions are meant as a guide only. They do not bind Draper, Inc. in any way and do not imply any responsibility of Draper, Inc. for improper installation or faulty workmanship at the jobsite.

Installation Tips

- ① When possible, install bolts with heads toward floor (threads up), or with heads toward front (threads facing rear of backstop).
- ② Use your project drawings, which will tell you everything from exact locations to what clamps to use. If the drawing is to scale, the scale can always be found at the bottom of the drawing.
- ③ Dimensions are referenced from Face of Bank, Center Line of Court or Center of Clamp. Refer to project drawings for dimensions. Remember to account for offset dimensions (Center of Clamp to Edge of Clamp) when marking beams for clamp placement.
- ④ Prior to assembly, distribute parts to the correct backstop locations; make sure you have the proper parts for each backstop location.
- ⑤ All Draper Gymnasium Equipment is supplied with Grade 5 hardware. Clamps are designed to be installed with the nuts and bolts "tight." Draper would consider tight to be torques between 40 ft-lbs and 60 ft-lbs.

How to Use This Manual

This manual covers installation of all Draper EZ-Fold® wall-mounted backstops, and is designed to be used in conjunction with project drawings. Project drawings show clamp numbers and positions for each backstop. Begin at step 1, the top, and work your way down, following instructions for clamps provided for each specific installation.

Tools Needed

- Block and tackle
- $\frac{9}{16}$ " and $\frac{3}{4}$ " wrenches, or socket wrenches, sizes $\frac{9}{16}$ " and $\frac{3}{4}$ "
- Chalk line
- Plumb bob or laser plumb pointer
- Tape measure (minimum 100')
- Needle-nose pliers
- Screwdrivers (Phillips and flat-head)
- Allen wrenches
- Impact tool
- Scaffolding and/or lift
- Carpenter's Level
- Electric drill ($\frac{9}{16}$ " and $\frac{9}{32}$ " bits)
- Electric saw
- Wire cutters

Operation

- ① On wall-mounted folding models (DGW and DUW), make sure the walls are cleared of any obstructions to proper operation.
- ② Make sure manual winches are located close to backstop, or at least in a position that allows the operator to see the backstop being raised or lowered.
- ③ Winches should be operated by qualified personnel. Locate winches where they are not easily reached, and keep manual or portable electric operators secured when not in use.
- ④ Use winches only for their original purpose; if equipment changes are necessary, contact Draper, Inc.
- ⑤ If you encounter a problem during installation or operation of your backstop, contact Draper, Inc. immediately.
- ⑥ Make sure wall is strong enough to support backstops.

Maintenance/Inspection

NOTE: EZ-Fold® backstops by Draper, Inc., are designed to operate for many years with a minimum of maintenance. However, you should periodically inspect your wall-mounted backstops to ensure they are in good repair and operating properly. Check backstops at least twice a year, depending on amount of use. You will find on page 7 a maintenance checklist. Detach, make copies, and hang this list in a convenient location to help keep track of inspections and repairs. If you encounter problems, or need to replace any parts, contact your dealer or Draper, Inc.

Wall/Wood Pads

- ① Check wall inside and out for cracks, crumbling mortar, or other signs of damage.
- ② Make sure wood wall pads are not pulling away from the wall.
- ③ Inspect wall pads for splits, chips, or other signs of damage or excessive wear. Make sure they are still strongly anchored, and that there has been no slippage.
- ④ Check hardware attachments to wood wall pads. Make sure there is no corrosion, and that all attachments are still tight.

Legs/Braces/Supports

- ① Inspect chain supports for corrosion, cracks, links pulling apart, or other signs of damage or excessive wear.
- ② Make sure chain swivels operate smoothly, and that they have not been bent out of shape.
- ③ Check leg attachments for DGW and DUW. Make sure they are not bent, and that the legs operate smoothly.
- ④ Inspect brace and leg attachments for SW and SWD models. Make sure they are still tightly attached, and there is no movement up and down or side-to-side.
- ⑤ Check telescoping cross-brace on DGW; make sure spring-loaded locking mechanism is functioning properly.
- ⑥ Make sure legs are still level, and that there are no cracks, dents, or bends. Also check for corrosion.

Winches

- ① Examine cable drum on winch for excessive wear or looseness. Ensure cable is wrapping correctly, and that "stacking" (cable wrapping unevenly in layers) does not occur.
- ② Inspect manual winch adaptor and socket on hand or electric operator for excessive wear (rounding of edges).
- ③ Check safety lock to make sure it keeps Manual Winch Adaptor in place.

- ④ Make sure winch is still properly mounted. If winch has slipped slightly, correct and tighten bolts using an impact wrench.

Please Note: Draper EZ-Fold® winches are self-lubricating. No periodic application of grease or oil is required.

Cable Run

- ① Check cable sheaves for excessive wear or looseness. Make sure cable is still passing properly through the sheave.
- ② Inspect cable clamps for tightness; Make sure there is no slippage.
- ③ Check aircraft cable for fraying. (Hint: One way to do this is by running an oily rag along the aircraft cable. The rag will snag on frays; it will also lubricate the cable.) If fraying is encountered, contact your dealer or Draper, Inc. for replacement. **Caution: Wear gloves when searching for frays.**

Backstop/Accessories

- ① Inspect backstop legs and frame. Make sure all bolts and clamps are tight and have not shifted. Check for cracks, corrosion, or other signs of damage or excessive wear.
- ② Make sure Side Braces are still at proper length.
- ③ Check Height Adjuster for loose clamps, or binding that keeps it from operating correctly.
- ④ Lubricate Inner Tubes of Height Adjusters with petroleum jelly.
- ⑤ Inspect bank and goal for cracks or bending. Also make sure top of rim is still 10' above the floor, and level.
- ⑥ Check padding for tears, missing pieces, or loose sections. Re-glue if necessary.

Winch Attachment/Wiring

Mounting Winch on a Flat Surface

- ① Four $\frac{9}{16}$ " dia. holes are provided for mounting. Fastener type and size required varies according to mounting surface but must be able to safely sustain all loads imposed by the backstop.

DO NOT USE LONG EXTENSION CORDS TO POWER THE WINCH. USE A MINIMUM OF 14/3 GAUGE MAXIMUM 100 FT WHILE INITIALLY CONNECTING THE WINCH DURING INSTALLATION PERIOD. RUNNING THE WINCH UNDER BAD POWER-VOLTAGE CONDITIONS WILL RESULT IN OVERHEATING AND DAMAGE TO THE CAPACITORS.

Please Note: Winch limit switches are pre-wired at the factory. Do not test-run the winch with limit switches bypassed: This may cause over-travel of the limit mechanism and result in damage to winch.

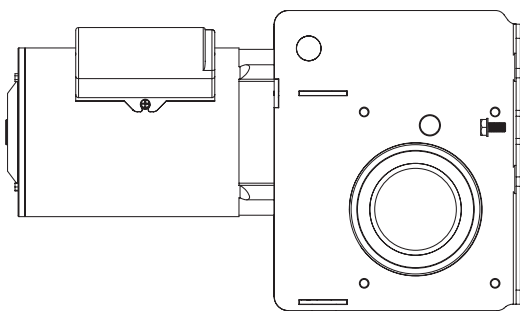

Figure W-1

Cable Installation (see Fig. W-2)

The winch is designed for standard $\frac{1}{4}$ " diameter 7 x 19 aircraft cable and has a hollow drum, which makes cable attachment simple and reliable. The cable passes through a hole in the drum and is prevented from pulling out by doubling the end back on itself and securing with a standard cable clamp.

- ① Jog winch to bring wire cable mounting hole in winch drum to top.
- ② Pass wire cable end from outside winch in through the cable port, then through hole in drum, into center of hollow drum. Pass enough cable through to pull the free end out the end of the drum.
- ③ Double cable end of cable back on itself and install clamp. Tighten nuts progressively to make sure clamp is fully secured.
- ④ Pull the cable back through the hole to snug the clamp back tight to the hole, inside the drum.
- ⑤ Run winch in "up" direction to wind on at least two turns of cable. (The pressure roller will lift by itself to allow the cable to pass under.) Make sure the cable starts properly in its groove, to ensure even winding of the cable.
- ⑥ Run the free end of the cable through the rigging system and attach it to the backstop attachment point.

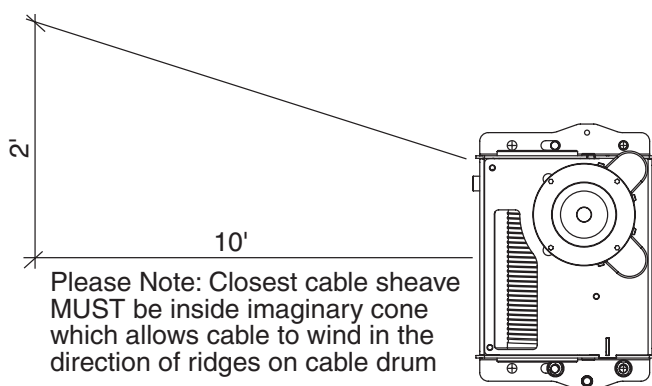

Figure W-2

Winch Wiring (see Wiring Diagram, Fig. W-3)

- ① Two $\frac{7}{8}$ " diameter knock-outs are provided, one on each side of the winch, to accept $\frac{1}{2}$ " conduit connectors and provide wire access to the electrical compartment at the bottom of winch case.
- ② Remove two screws securing the lower cover, slide the cover out from its locating tabs and withdraw it. The wiring diagram is on the inside surface of the cover. Field connections are made directly to the terminal block. We recommend at least 12-gauge conductor wire as a power supply line to the winch. All circuit breakers must be dedicated. Check for voltage drops under load (limit switches are in same compartment).

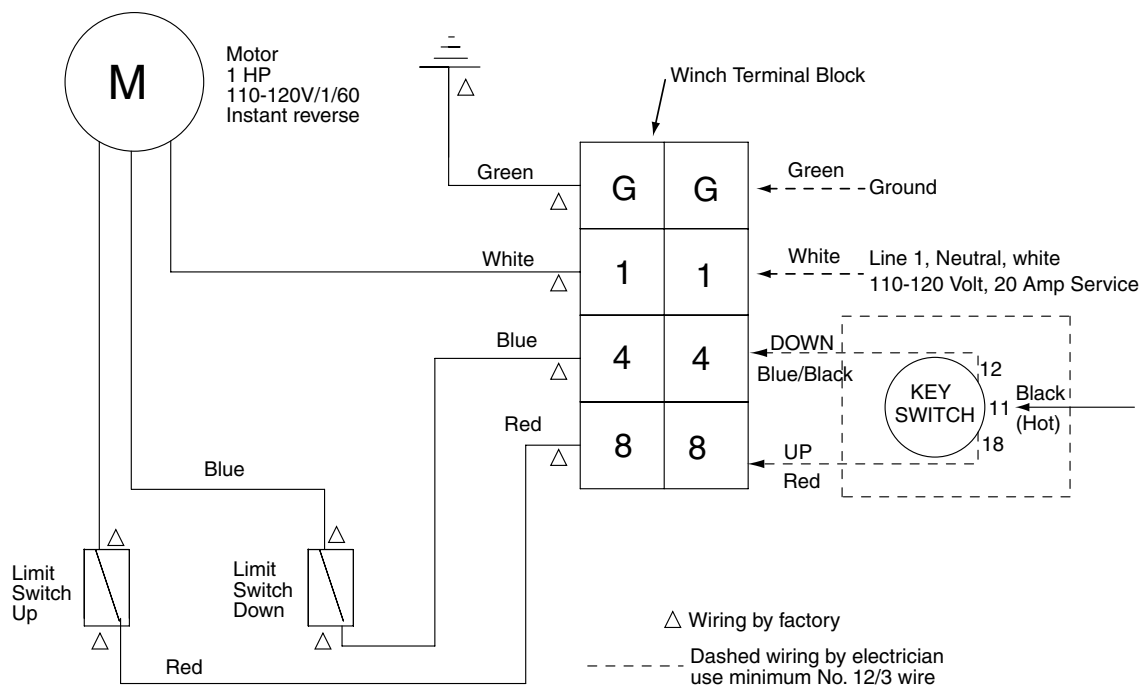

Figure W-3—Wiring Diagram

Lowering Backstop in Case of Power Failure (see Fig. W-4)

The winch motor comes standard with an internal thread in the end of the shaft, behind the removable end cap.

- 1 Remove end cap by prying it off with a flat screwdriver).
- 2 Screw $\frac{5}{16}$ " socket head cap screw into threaded hole in shaft, or $\frac{5}{16}$ "-18 coarse thread hex bolt. Turning screw **clockwise** slowly lowers backstop.

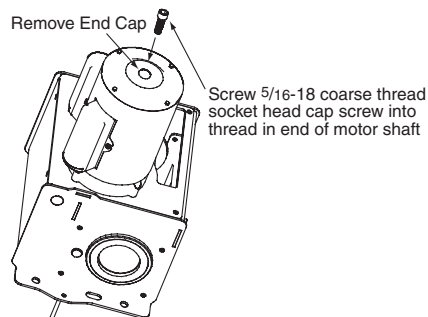

Figure W-4

- 5 Run the backstop up and down again to check the settings.
- 6 Make a final check to make sure that all fasteners are tight and the rope is tracking properly in the drum grooves before putting the winch into use.

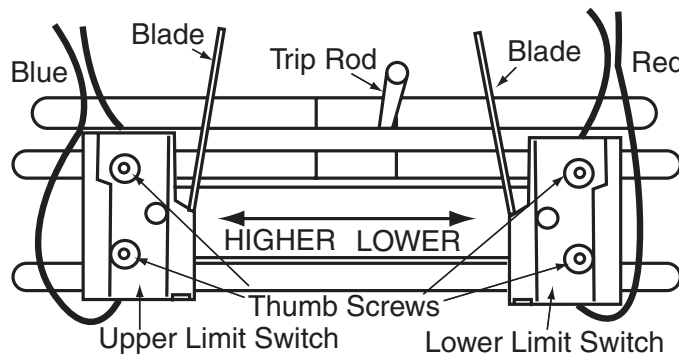

Figure W-5

Limit Switch Adjustment (See Figs. W-5 and W-6)

Please Note: One upper and one lower travel limit switch is provided. Proper adjustment is simple and quick with the following procedure. Always shut power off from the winch when working inside the electrical compartment. The cover has been designed for quick removal to simplify limit switch adjustment.

- 1 Run the winch in the "up" direction to raise the backstop to the desired (fully raised) position and stop it in this position. Turn off the power to the winch and remove the electrical compartment cover. (2 screws)
- 2 Loosen the two thumb nuts holding the upper limit switch.
- 3 Slide the upper limit switch across until the blade contacts the limit trip rod, then slide it a little further until an audible click is heard as the switch opens. Tighten the thumb nuts. The top limit is now set.
- 4 Temporarily install the cover and run the backstop down to the desired lower stop position and set the lower limit switch in the same way.

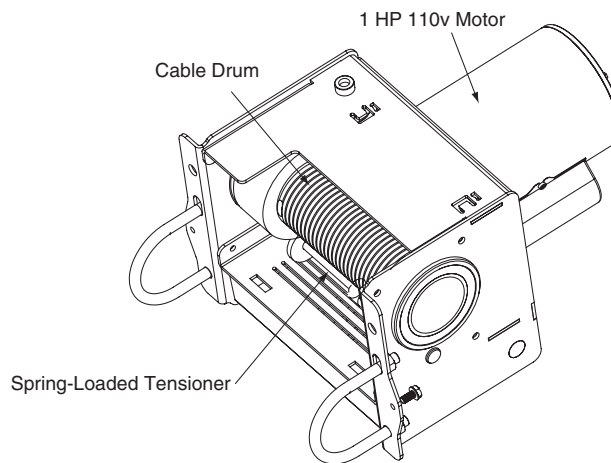

Figure W-6

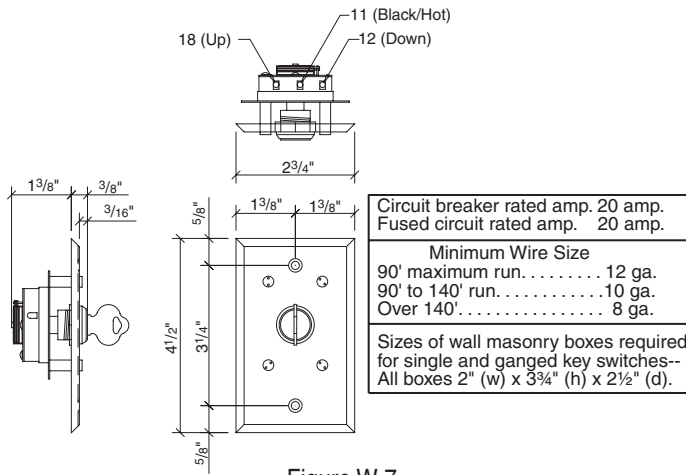

Figure W-7

Caution

- ① All wiring from junction box to Key Switch must be completed by electrical contractor (see figures W-3 and W-7).
- ② DO NOT wire winch into junction box until making sure power to the junction box is disconnected (circuit breaker is off).
- ③ If key switch operates winch in reverse ("Down" is "Up"), turn off power to junction box and switch wires.
- ④ Install key switch so operator has unobstructed view of backstops.

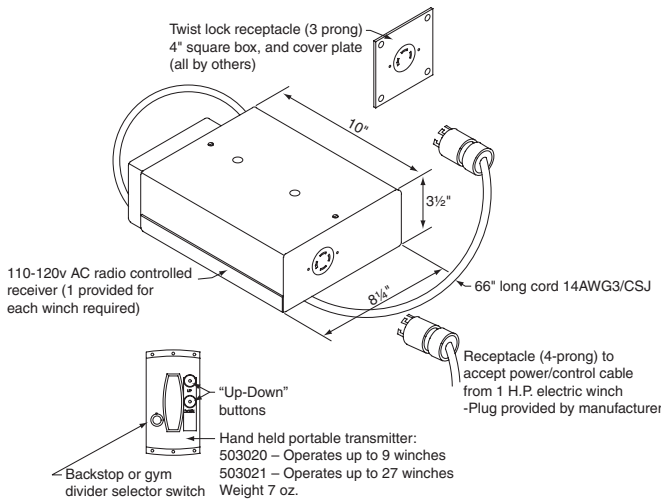

Figure W-8—503023 EZ Power Electronic Remote Control

503029 Posilok™ Safety Belt:

- ① Bolt mounting brackets to POSILOK with flanges turned outward. Use 3/8" x 1" bolts, lock washers and nuts provided.
- ② Bolt to wood wall pads according to installation drawings using mounting hardware (by others) determined according to site conditions.

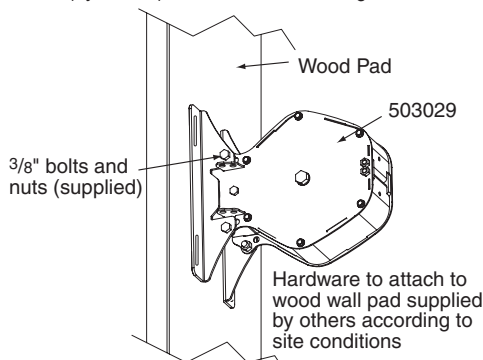

Figure W-9—503029 Posilok Safety Belt

Manual Winch

- ① Find location according to project drawings.
- ② Four 9/16" diameter holes are provided for mounting the unit. The fastener type and size required will vary according to the type of mounting surface but must be adequate to safely sustain all loads imposed by the backstop system.
The Architect/ Engineer for the building should be consulted to determine the proper method and size of fastener necessary.
Note: The winch is designed for standard 1/4" diameter 7 x 19 aircraft cable and has a hollow drum, which makes rope attachment simple and reliable. The rope passes through a hole in the drum and is prevented from pulling out by doubling the end back on itself and securing with a standard rope clamp.
- ③ Turn the winch handle to bring the wire rope mounting hole in the winch drum to the top.
- ④ Pass the wire rope end from outside the winch in through the rope port and then through the hole in the drum, into the center of the hollow drum. Pass enough cable through to allow you to pull the free end out the end of the drum.
- ⑤ Double the end of the cable back on itself and install the clamp supplied, tightening the nuts progressively to make sure that the clamp is fully secured.
- ⑥ Pull the rope back through the hole to snug the clamp back tight to the hole, inside the drum.
- ⑦ Wind on at least two turns of rope. (The pressure roller will lift by itself to allow the rope to pass under.) Make sure that the rope starts properly in its groove, to ensure even winding of the cable.

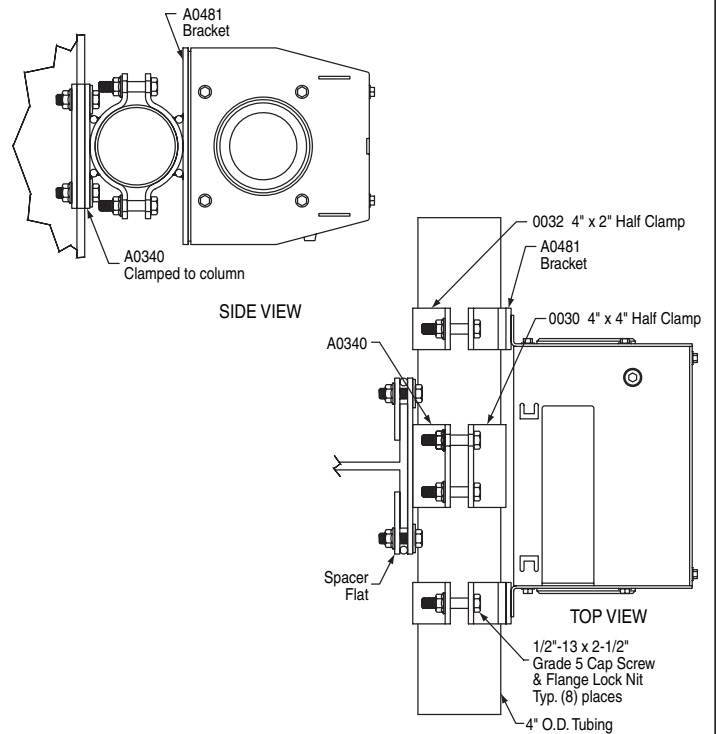

Figure W-10—A0481 Winch Column Mount

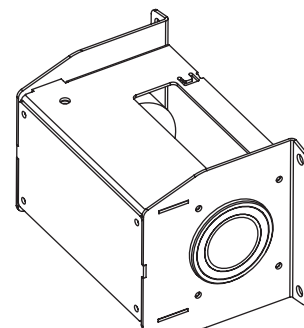

Figure W-11—Manual Winch

Backboard padding.

NOTE: This step can be completed at any point during installation; the most convenient time is during bank/goal assembly, prior to bank attachment.

A0253/A0264 (glue-on:)

- ① Hold each half of pad in place and mark pads for trimming around support structure (if required).
- ② When required trimming is complete, apply coat of glue to inside of padding. Allow glue to dry until it becomes tacky (less than a minute).
- ③ While glue is drying on padding, apply a coat to the backboard.
- ④ Attach padding to backboard.

A0142 (bolt-on)

- ① Hold each half of pad in place and mark pads for trimming around support structure (if required).
- ② Trim pads.
- ③ Hold pads in proper position and mark holes for drilling into board framework (8 holes per backboard). Make sure the holes closest to the center of the backboard (under the rim) are positioned so that the pads join fully in the middle.

CAUTION: On all glass or acrylic backboards, use holes nearest the rear of the backboard to avoid possible damage.

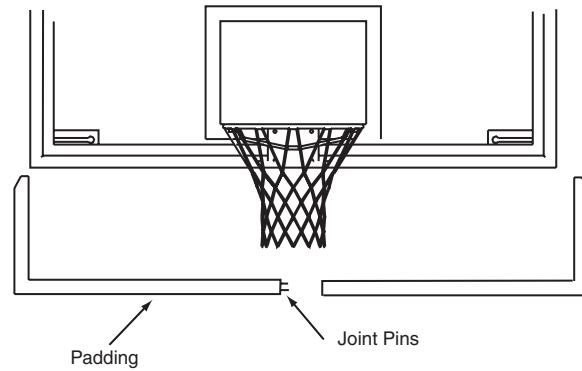
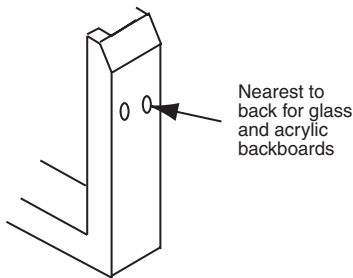

- ④ Drill holes (minimum 1/4", maximum 5/16") at marked locations. Drill completely through all framework structure.

- ⑤ IF PROVIDED: Use joint pins in pad half ends to eliminate sagging.

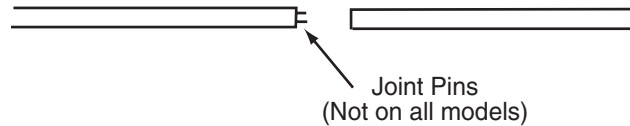

- ⑥ Attach pads using appropriate screws (three sizes provided). Make sure all washers and lock washers are used, to avoid loosening.
- ⑦ If needed, trim for goal clearance. (Some backboard and goal combinations will require extra trimming of pads to provide for goal clearance.)

CAUTION

Glue used to attach Draper backboard padding is extremely flammable. Keep away from heat and flame. Keep out of reach of children. Avoid prolonged exposure to fumes: Use in a well-ventilated area.

Before leaving the jobsite:

- ① Touch up any scratches caused during installation or shipping.
- ② Remove tools and scrap from job site.
- ③ Ensure all backstops are level and in accordance with measurements on project drawings.
- ④ Tighten all bolts, and ensure that backstops are ready for use.
- ⑤ Verify that all backstops are functioning properly.
- ⑥ Set all limit switches on electric winches.
- ⑦ Coat Inner Tubes of Height Adjusters with petroleum jelly.
- ⑧ Make sure all chalk lines are wiped from floor.
- ⑨ Dispose of boxes and packing materials.
- ⑩ Explain proper winch and backstop maintenance and operation to the customer.

NOTE: If you encounter any difficulties installing or servicing your EZ-Fold® Wall-Mounted Backstop by Draper, Inc., contact your dealer or Draper, Inc. at (765) 987-7999 or fax (765) 987-7142.

EZ-Fold® Wall-Mounted Backstops by Draper

Backstop Model: _____

Inspection/Maintenance List

Backstop Number: _____

Periodically inspect your backstops and all related equipment and attachments. Frequency of inspections depends on use of the equipment. Use guidelines mentioned earlier in this manual when conducting inspections.

Below is a checklist to assist you in keeping a record of backstop inspections and maintenance. Cut, copy and post this page as a record of previous inspections and equipment repairs on each backstop. Place a checkmark or enter information in the appropriate box:

Inspection Item	Date	Satisfactory	Cleaned	Needs Repaired/Replaced	Problem Encountered
Winch Drum					
Winch Belt					
Winch Attachment					
Aircraft Cable					
Pulleys/Sheaves					
Back/Front Braces					
Side Braces					
Jackknife					
Wall Attachments					
Chains					
Turnbuckles					
Cable Clamps					
Backstop Clamps					
Hangers					
Frame					
Height Adjuster					
Goal					
Bank					
Backboard Padding					
Finish					
Nets					
Latches					

① Wood Wall Pad Installation

NOTE: Draper, Inc., is not responsible for wall strength. Attachment method to be determined by project architect/engineer.

Note: Drawings will show locations of wall pads. Before drilling, make sure there are no obstructions or electrical wiring where you will be drilling. Spread plastic throws on inside floor before drilling.

- ① Mark wall attachment locations on 0037 Wood Wall Pads (see figure at right). These may be adjusted to meet field conditions. (If thru-bolts are present, lay out holes to match bolt locations.) Drill four 9/16" diameter holes if anchor bolts are 1/2" dia. or larger, as needed.
- ② Position part to be attached to wood pad on center line. Mark hole locations, and drill required number of 9/16" holes.
- ③ Turn wood pad to unfinished side, countersink 9/16" holes so carriage bolt heads will be flush with wood pad (1 1/4" diameter x 1/4" deep).
- ④ Place wood pad against wall and mark wall where anchor holes are drilled in wood pad.
- ⑤ Drill holes in wall as required.
- ⑥ Install 1/2"-13 x 2 1/2" carriage bolts in 9/16" holes from back side of pad.
- ⑦ Place wood pad on wall and attach with type of wall bolt appropriate for field conditions.
- ⑧ Tighten wall bolts with hand wrench.

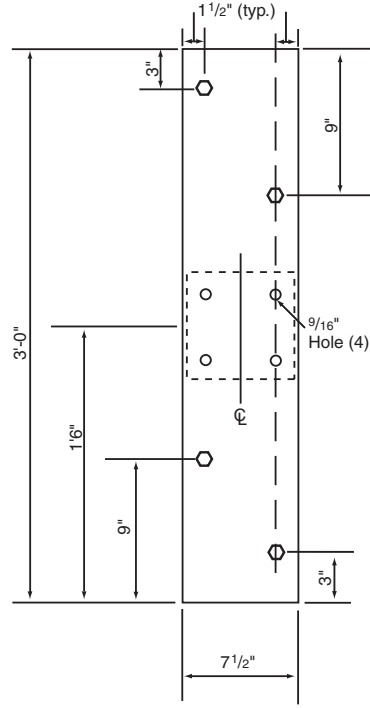

0037 3' Wood Wall Pad

- ⬡ = Suggested wall mounting bolt locations.
- = Suggested hanger bolt mounting locations (9/16" dia.).

- ⬡ = Suggested wall mounting bolt locations.
- = Suggested hanger bolt mounting locations (9/16" dia.).

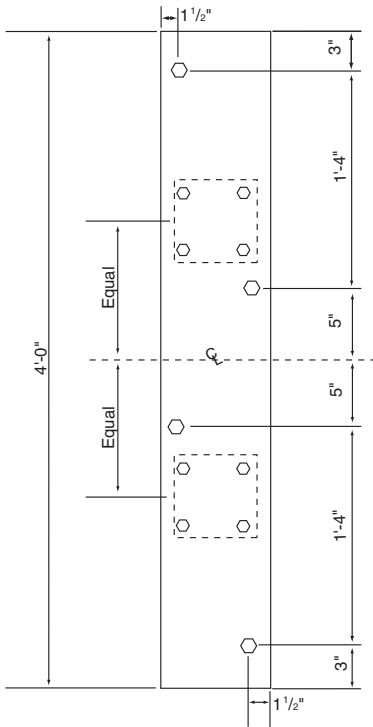

0302 4' Wall Pad

- ⬡ = Suggested wall mounting bolt locations.
- = Suggested hanger bolt mounting locations (9/16" dia.).

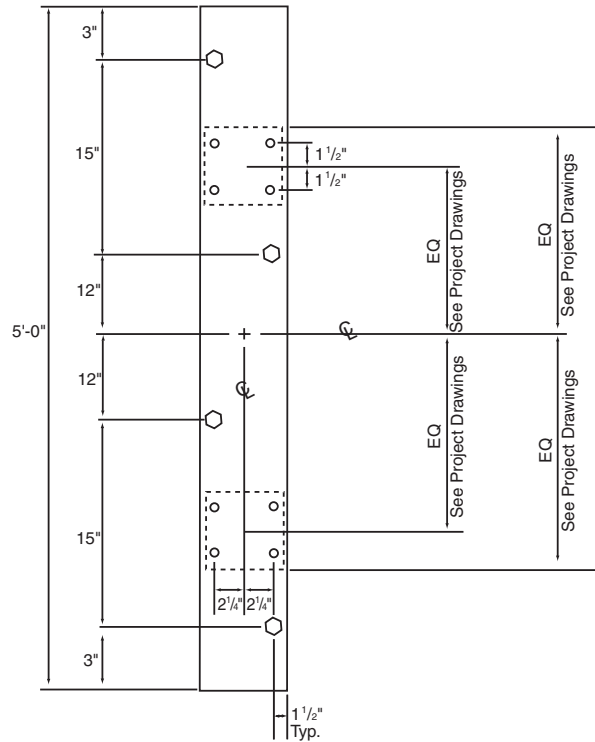

0274 5' Wall Pad

See next page for 7' wall pad. 5' and 6' wall pads also available. Contact Draper or see your project drawings.

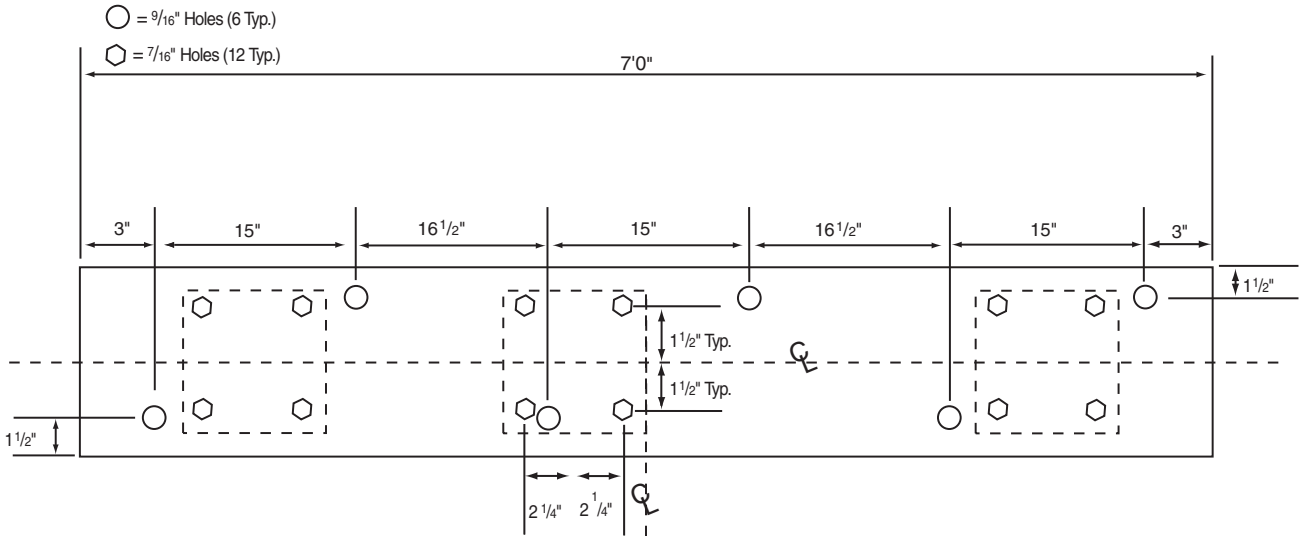

7' Wall Pad (for use with DUW)

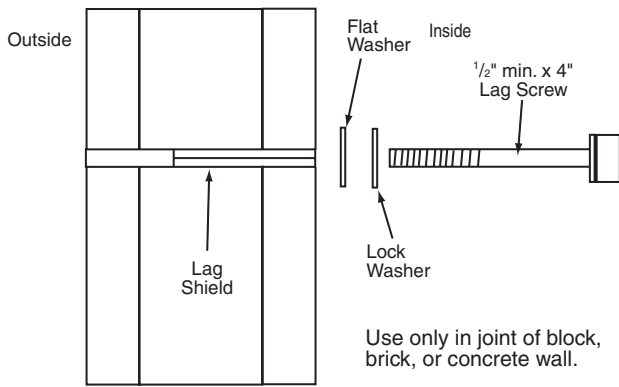

Lag Screw with Lag Shield

NOTE: Install Lag Shield first, using a hammer to sink it into pre-drilled hole.

Use only in joint of block, brick, or concrete wall.

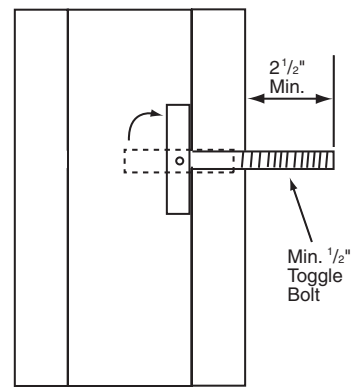

Toggle Bolt

NOTE: Insert Toggle Bolt into hole far enough to allow head to rotate, then pull flush against inside of wall.

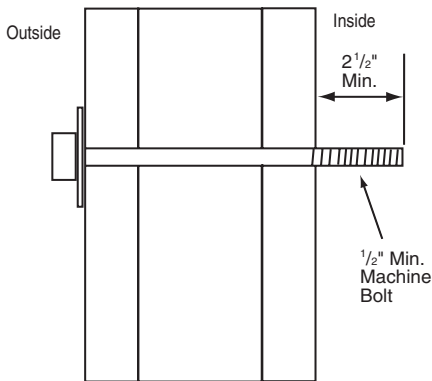

Through Bolt

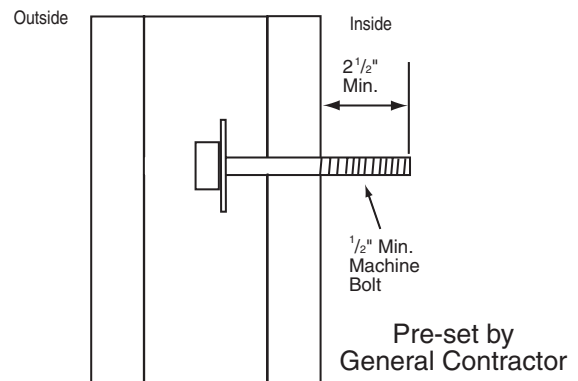

Set-in Bolt

NOTE: Attachment method determined by project architect/engineer. Attachment hardware provided by others.

② Attach support mounts and Cable Sheaves to Wall Pads.

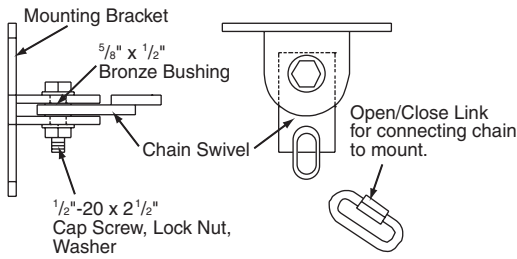

A0309 Wall Mount for DGW chain supports.

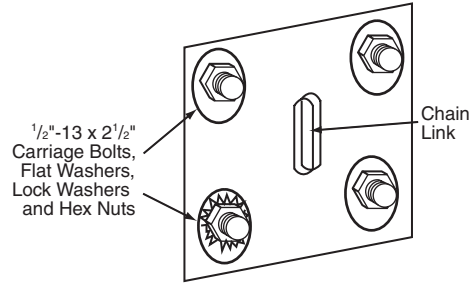

Wall chain mount for use with 7' wood wall pad on DUW and 36" Wood Wall Pad on SW extensions of over 3' and SWD.

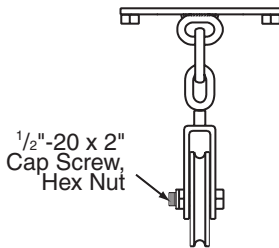

A0339 Cable Sheave for DUW.

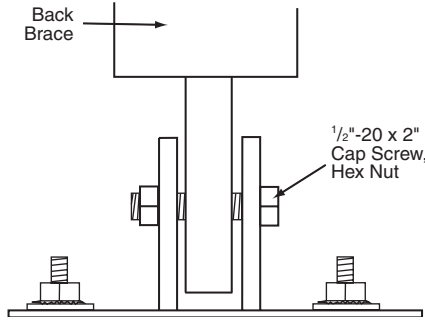

A0301 Upper Back Brace Hanger for TSW

③ Install leg mounts to Wall Pads.

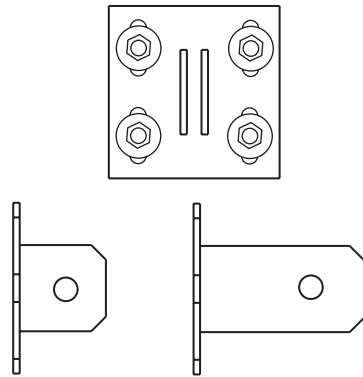

A0320 (Short) A0323 (Long)

A0320/A0323 mounts for DUW.

NOTE: Install SHORT LUGS on the top legs.

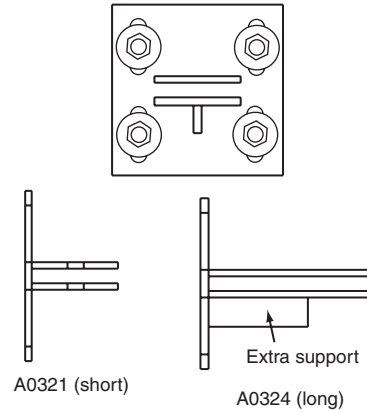

A0321 (short) A0324 (long)

A0321/A0324 mounts for DGW.

NOTE: Install SHORT LUGS on side in direction of fold (right side for right fold, left side for left fold).

⑤ Assemble/attach Leg Frames.

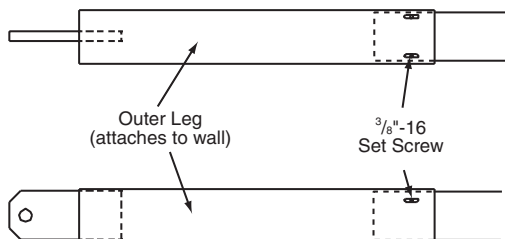

Leg for DGW and DUW.

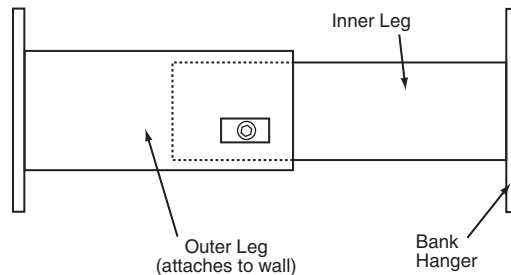

Leg for SW, SWD.

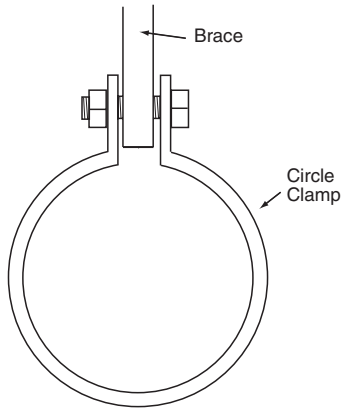

0299 Circle Clamp (for attachment of vertical Braces).

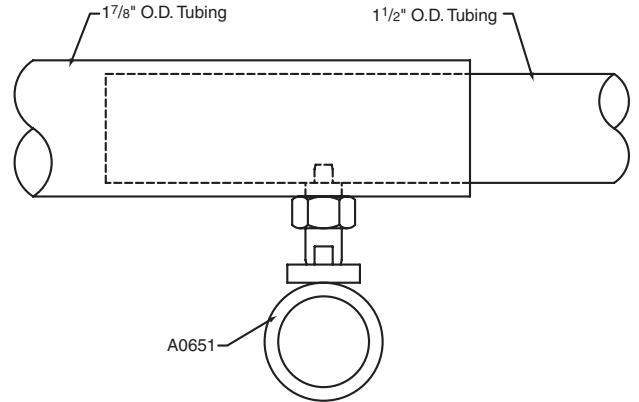

0651 (for attachment of horizontal Braces, including movable, locking Kick Brace on DGW).

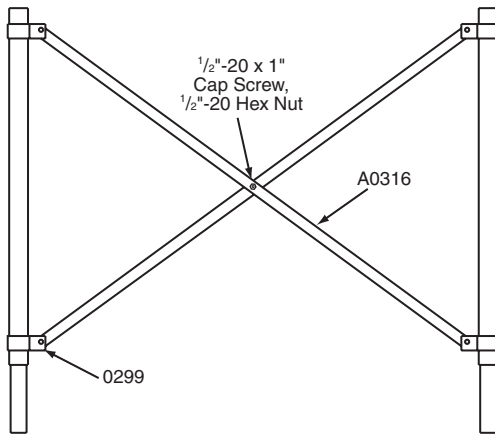

Cross Brace (top view), an example of horizontal braces on Wall-Mounted Frames.

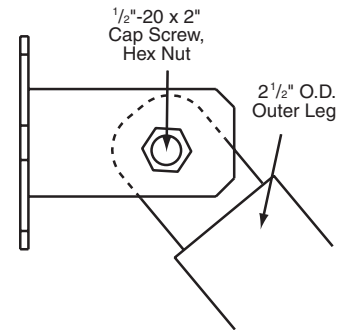

A0320/A0323 Leg attachment for DUW.

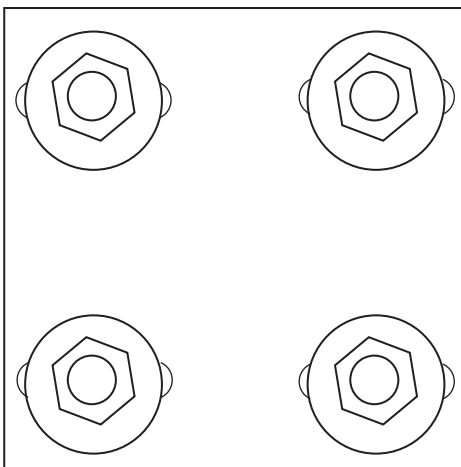

A0317 For use on SW/SWD

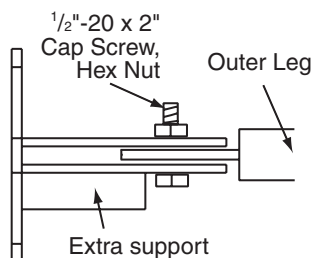

A0321/A0324 Leg attachment for DGW.

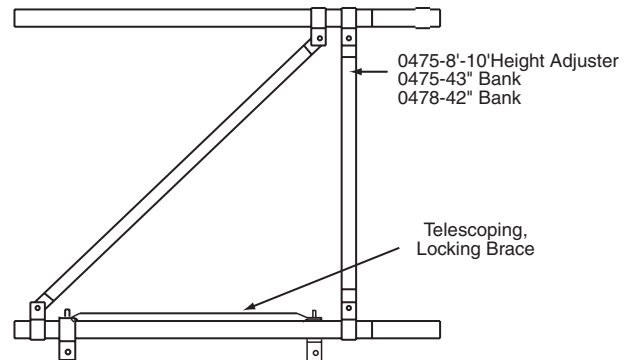

Example of vertical braces on Wall-Mount Frames (side view), including DGW telescoping, locking brace.

Please Note: To install telescoping brace, screw spring-loaded pin into hole provided on outer tube so that the head of the mechanism is toward the floor. slip inner tube into outer tube. Spring-loaded pin will pop into place. To fold, use manual height adjuster crank to pull spring-loaded pin down, then manually push backstop toward wall.

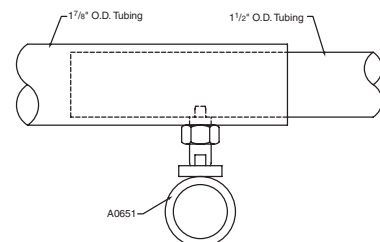

A0651

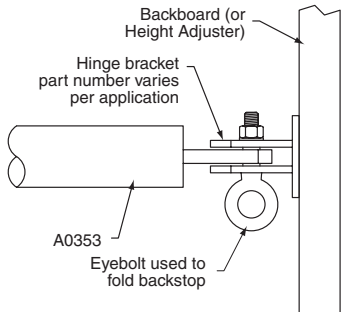

Eye bolt used to fold backstop (DGW).

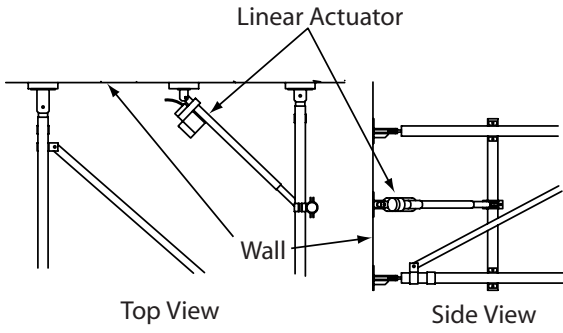

Linear Actuator used to fold backstop (DGW-E).

⑥ Attach Chain Supports to Backstop (SW, SWD, DGW, and DUW).

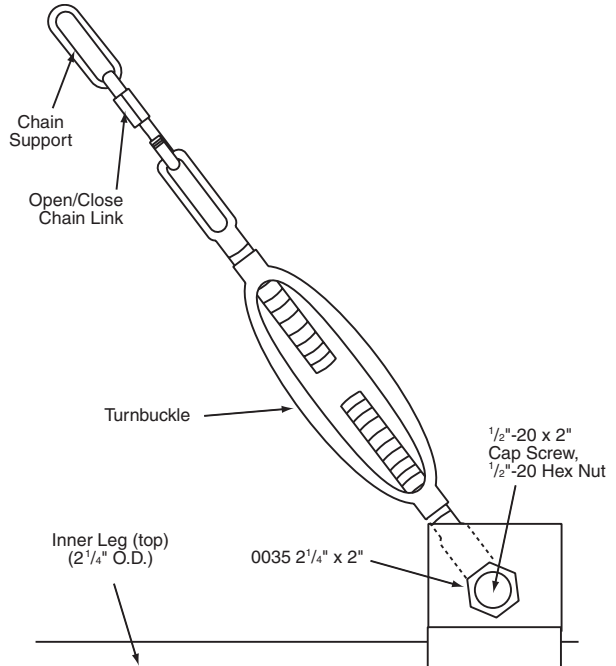

⑦ Attach Bank Hangers to Bank.

NOTE: If installing a Height Adjuster, see separate assembly instructions. If this is an SW model, skip this step.

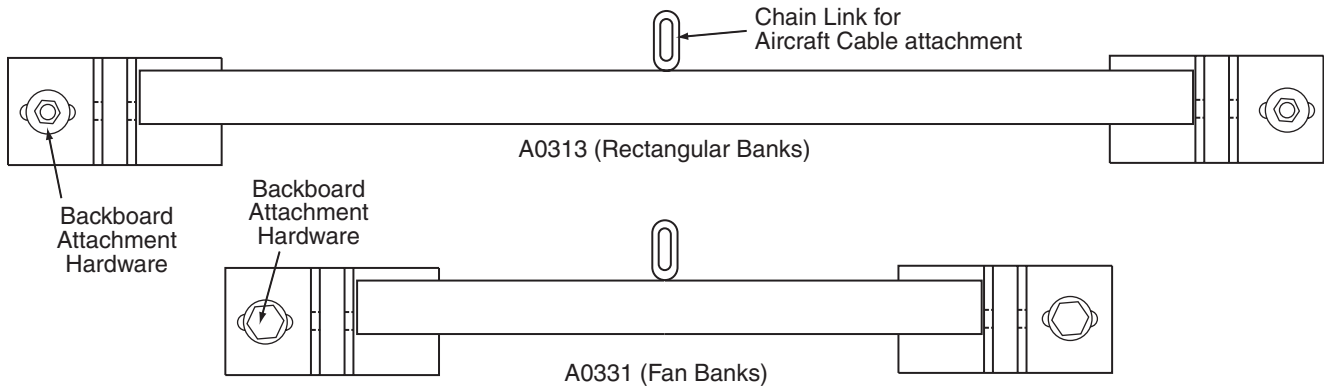

Upper Bank Hangers for DUW (NOTE: some Fan Banks require Carriage Bolts).

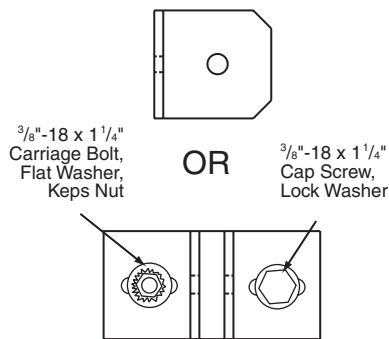

A0315 DUW Short Bank Hangers (for bottom)

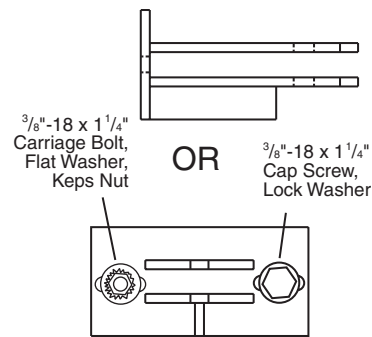

A0355 DGW Long Bank Hanger (for side in direction of fold)

NOTE: All Bank Hangers use same Carriage Bolt or Cap Screw combinations.

⑧ Assemble and attach Height Adjuster or Goal Brace (SWD), Bank, and Goal. (See separate instructions for Height Adjuster assembly.)

NOTE: You cannot use a Goal Brace and Height Adjuster on the same backstop.

① Bolt Goal to Bank and Goal Brace (Direct Mount Goal Brace on SWD).

TIP: Assemble Bank/Goal/Height Adjuster/Goal Brace face down on sawhorses, then hoist and attach.

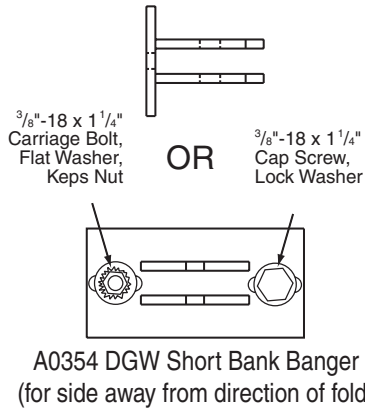

NOTE: Use lift to raise and attach Bank Assembly.

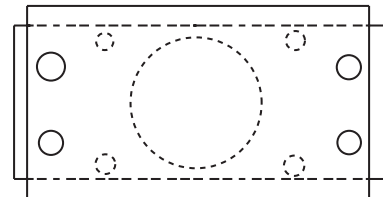
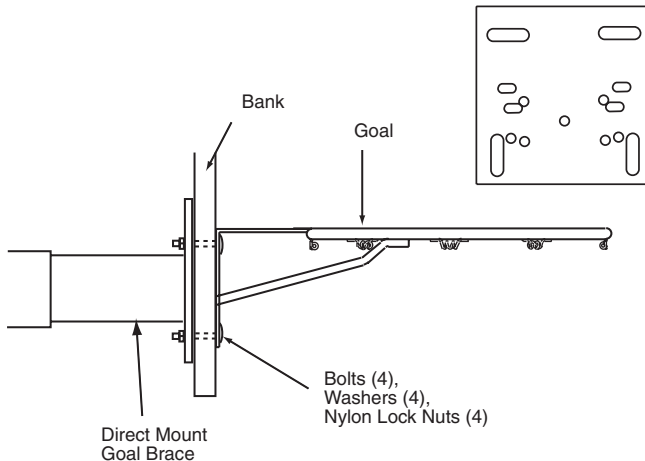
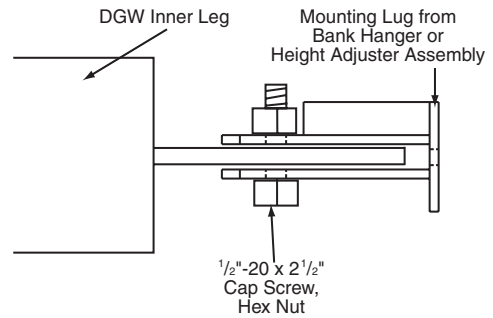
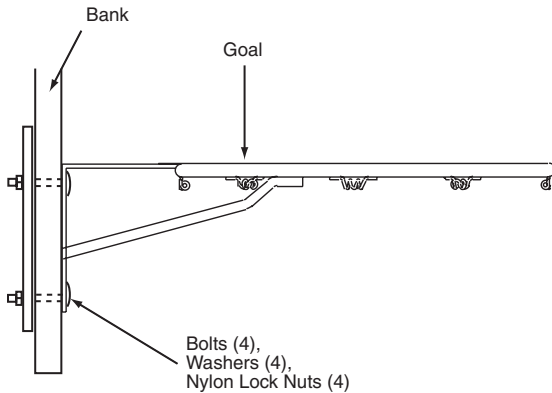
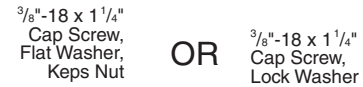
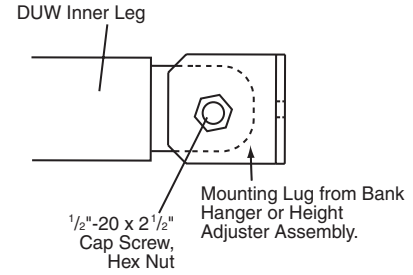

Attention: On glass backboards, Goal Plate Bushings are properly tightened during factory assembly. Installer should never tighten these bushings as excessive torque may cause damage to the glass.

SW

0299 Circle Clamp

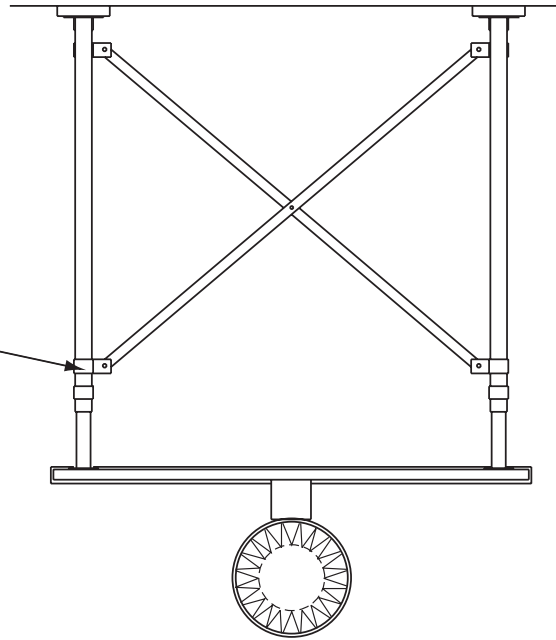

Top View

1/4" Chain

0035 Circle Clamp

0274 5'-0" Wood Wall Pad

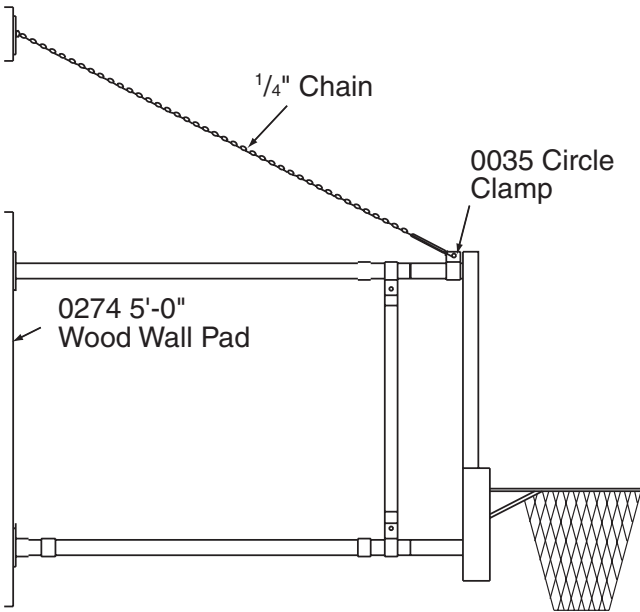

Side View

A0313 7'-0" Wood Wall Pad

A0303

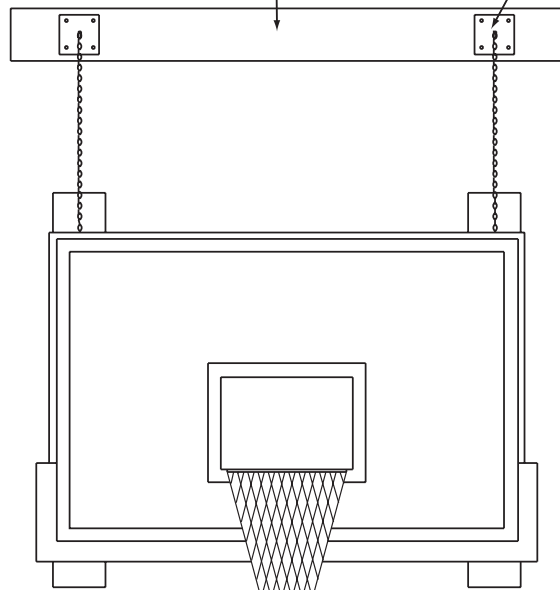

Front View

INSTALLATION NOTE: Attach and build legs and braces out from the wall. Assemble Bank, Goal, and Height Adjuster (if included), hoist, and attach.

SWD

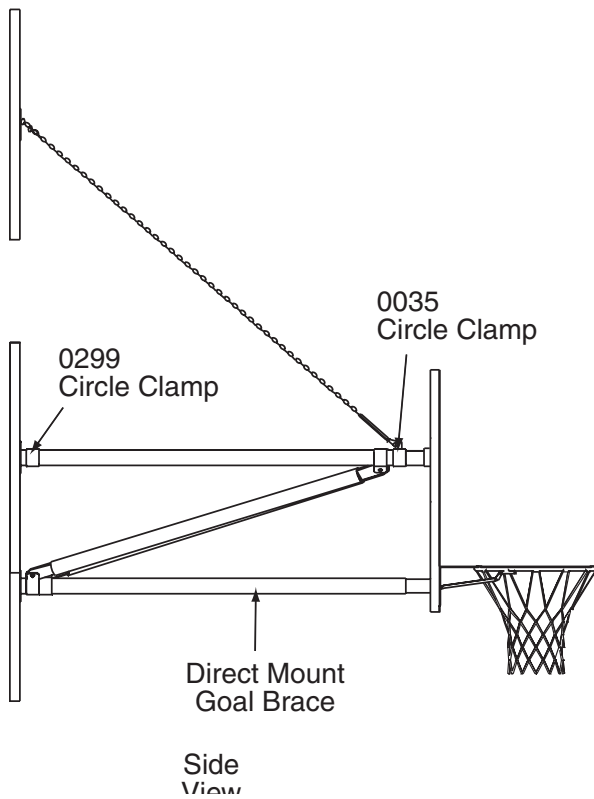
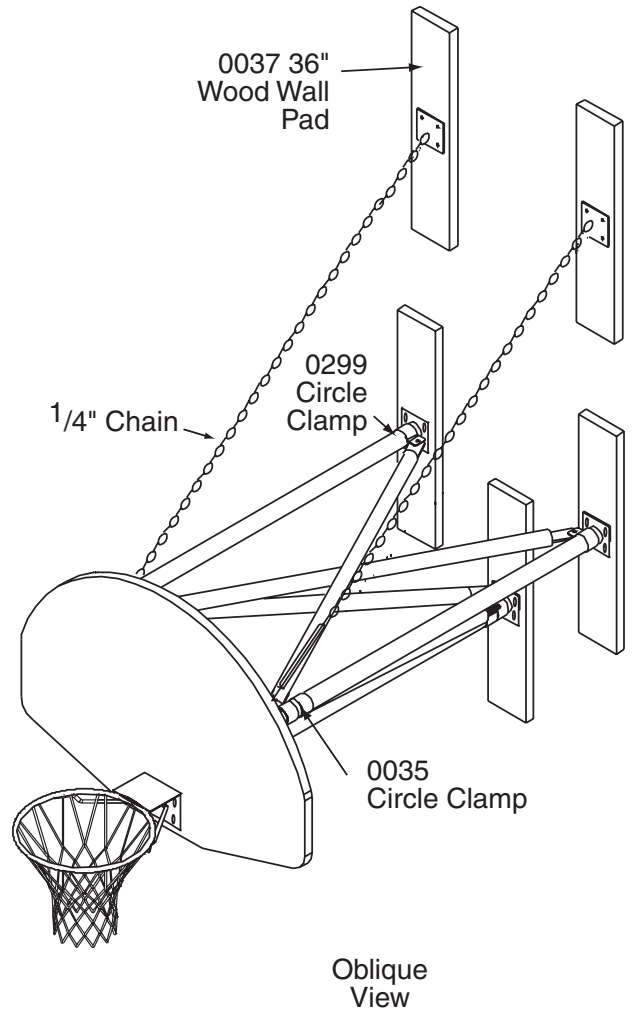
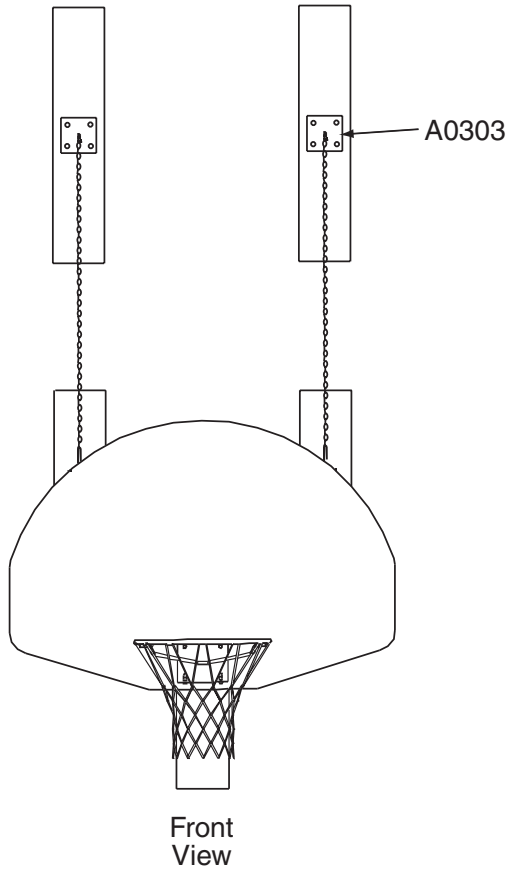

INSTALLATION NOTE: Attach/build legs and Direct Mount Goal Brace from the wall out. Assemble Bank and Goal, then hoist and attach.

DGW

Please Note: To install telescoping brace, screw spring-loaded pin into hole provided on outer tube so that the head of the mechanism is toward the floor. Slip inner tube into outer tube. Spring-loaded pin will pop into place. To fold, use manual height adjuster crank to pull spring-loaded pin down, then manually push backstop toward wall.

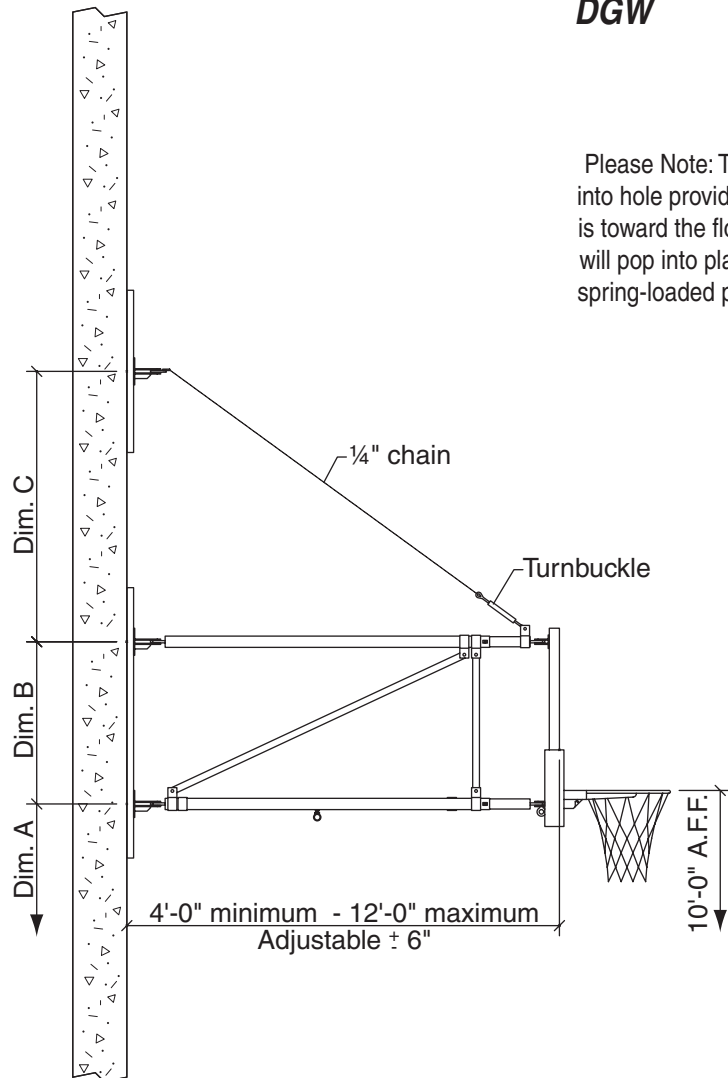

INSTALLATION NOTE: Attach and build legs from the wall out. Assemble Bank, Goal, and Height Adjuster, hoist and attach.

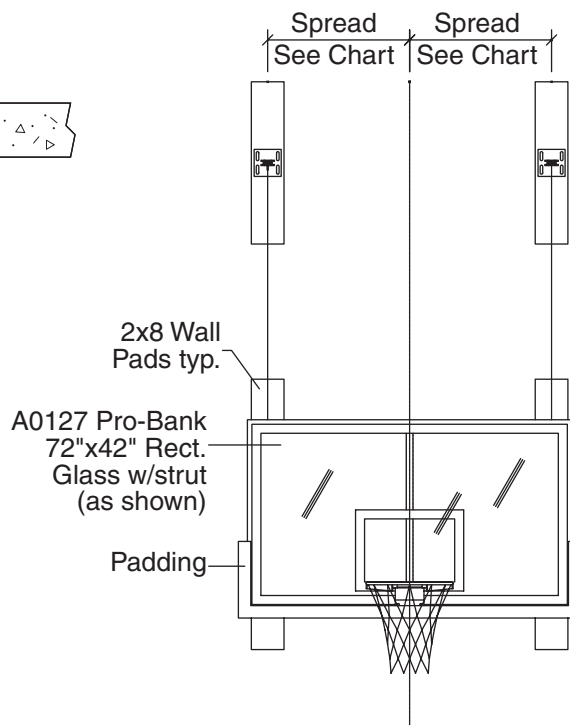
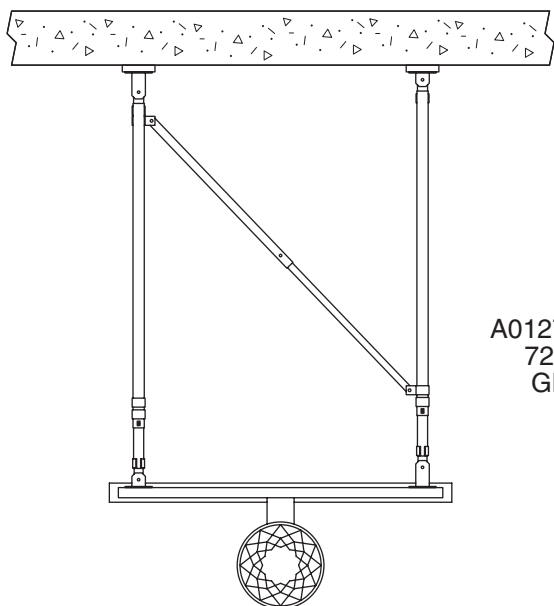

DGW-E

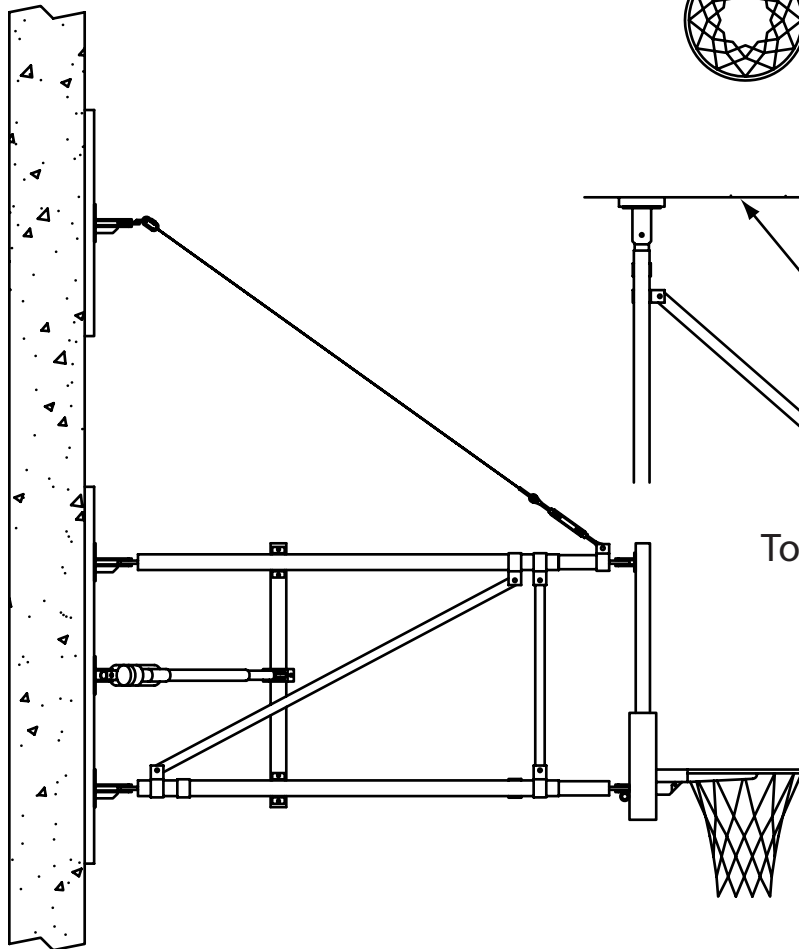
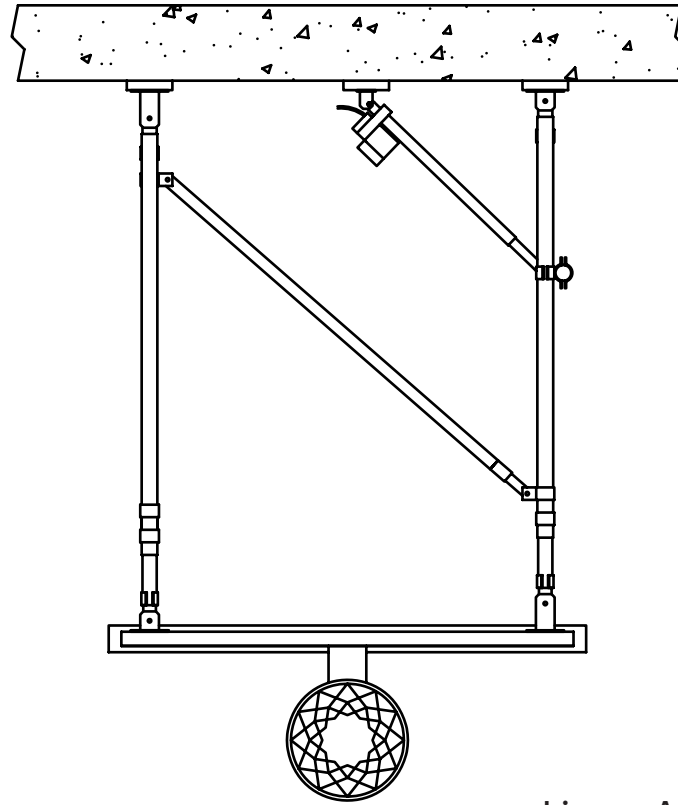

Linear Actuator

Wall

Top View

Side View

DUW

INSTALLATION NOTE: Attach and build legs from the wall out. Assemble Bank, Goal, and Height Adjuster, hoist and attach.

