

SPALDING®

**Slammer Flex Goal II
Model # 411-507**

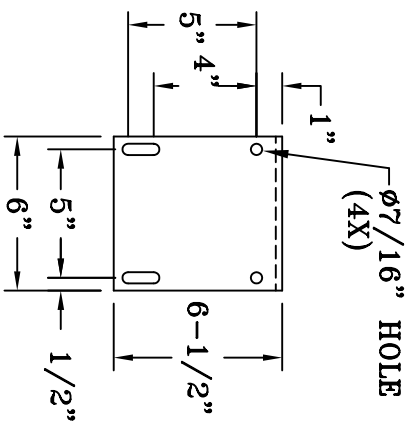

GOAL MOUNTING PATTERN

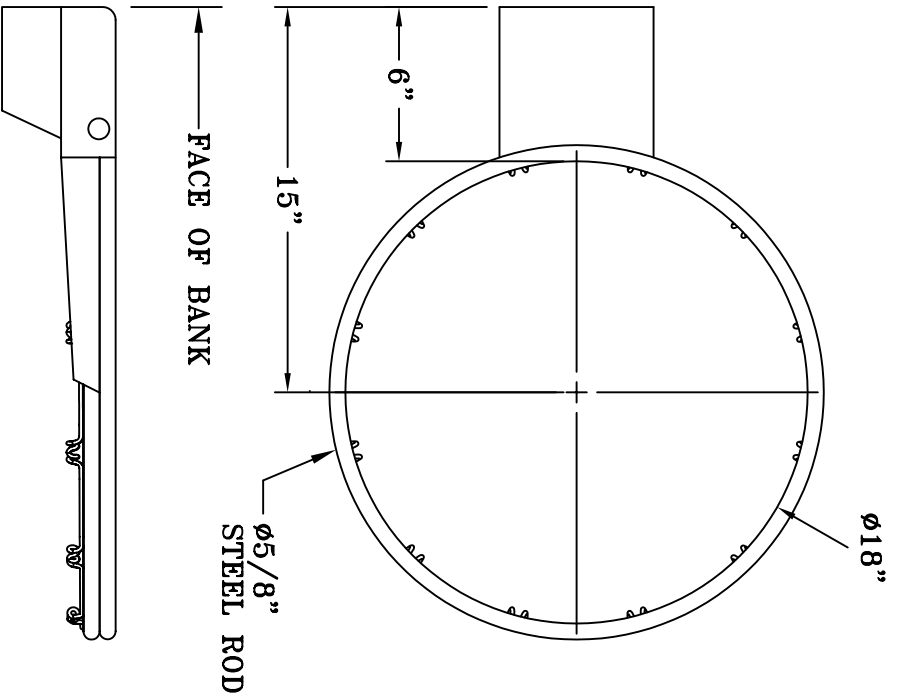
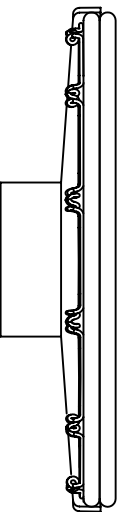

SLAMMER FLEX II

DO NOT SCALE

MODEL # 0411507



SPALDING SPECIFICATIONS

DATE: 01/01/06

MODEL NUMBER: 0411507

DESCRIPTION: Slammer Flex Goal II

SPECIFICATIONS:

Goal shall be designed to absorb shock loads due to "dunking" or hanging on the goal.

Goal shall incorporate a reflex mechanism to permit pivoting downward when excessive loads are put on the ring. Goal shall be spring loaded to return to the original position. The goal design shall allow spring preload to be adjusted to compensate for wear.

Rim shall be made of two 5/8" cold rolled steel formed to make an 18" inside diameter ring with a 600 lb. bend strength. The two rings shall be welded together to make a stiffer, more rigid goal.

Goal shall have a wrap around brace over 50% of the ring circumference for maximum strength.

Mounting hardware and standard net included.

Goal shall have continuous "ram horn" no-ties for easy net installation.

Goal shall have a universal standard mounting pattern (5" x 5" and 5" x 4") for attachment to any backboard with these mounting dimensions.

Goal shall have a one year warranty. Covers the reflex mechanism and ring from defects in workmanship. Warranty not offered on breakaway goals placed outdoors, or if used in a way not intended.

Shipping weight: 30 lbs.

[View Spec Print](#)