

Retrofit Instructions

8'-10' Basketball Backstop Height Adjuster by Draper

Caution

- ① Locate and identify all pieces. Please note that clamps are not attached to main unit.
- ② Do not paint inner slip tubes.
- ③ For electric operators, make sure Actuator Tube is vertically level.
- ④ Electric Height Adjuster operates on 110-120V, 60-Hz current.
- ⑤ Make sure electric operator is disconnected from power before beginning installation.
- ⑥ Tools: You will need $\frac{3}{4}$ " and $\frac{9}{16}$ " socket wrenches, and $\frac{3}{4}$ " and $\frac{9}{16}$ " wrenches or an adjustable wrench.
- ⑦ For manual units, be sure to apply lubricant (included) to T-Nut after installing threaded rod assembly.

Retrofitting Electric Operator to Manual Height Adjuster

- ① Manually crank backboard down to lowest height (this takes the weight off the unit; do not attempt to retrofit with backboard at normal 10' height).
- ② Remove the Threaded Rod Assembly and Nut Carrier Assembly.
Please Note: While one person can accomplish this, two people are recommended—one to hold the Threaded Rod Assembly in place, the other to remove bolts.
- ③ Attach brackets for electric operator (see Fig. 1). Upper Actuator Bracket attaches to T-Stem or frame of non-T backstop so that the center of the bracket is 12'10 $\frac{1}{2}$ " above the finished floor for rectangular backboards, and 12'11 $\frac{3}{4}$ " for fan backboards. Lower Actuator Bracket attaches to lower plate of 8'-10' unit.

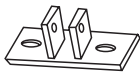

Lower Actuator Bracket (all units)

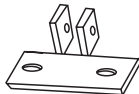

Upper Actuator Bracket (Wall Mount)

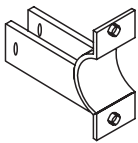

Upper Actuator Mount (Double Drop)

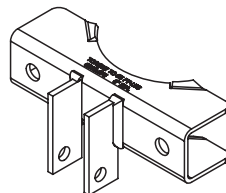

Upper Actuator Mount (T-Stem)

Figure 1

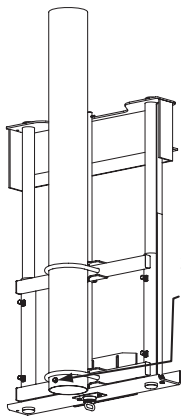

Nuts that attach the u-bolts and saddle brackets to the backstop should be tightened to 85 ft-lbs.

After drilling through Tube, thread a $\frac{3}{8}$ -16 x 1" long bolt through hole below bottom U-Bolt. Bolts are provided with Height Adjuster.

Figure 2

DRAPER®

411 S. Pearl St., Spiceland, IN 47385 USA ■ 765-987-7999
www.draperinc.com ■ fax 765-987-7142

Copyright © 2009 Draper Inc. Form EZ-HeightAdjusterRetrofit_Inst09-R2 Printed in U.S.A.

- ④ Attach electric operator to Upper Actuator Bracket.
- ⑤ Use test cord (not included) to extend Actuator Tube to match distance between brackets.
- ⑥ Attach Actuator Tube to Lower Actuator Bracket.
Please Note: Make sure Actuator Tube is vertically plumb.
- ⑦ Use test cord to test operation.
- ⑧ Complete wiring using wiring diagram on page 2.
- ⑨ Adjusts limits of travel (8'-10'). (See directions at right.)

Retrofitting Threaded Rod Assembly to Electric Unit

- ① Lower backboard to lowest height (this takes the weight off the unit; do not attempt to retrofit with backboard at normal 10' height).
- ② Beginning at the bottom of the unit, remove brackets which are holding Electric Operator and Actuator Tube to the Height Adjuster (see Fig. 1).
Please Note: While one person can accomplish this, two people are recommended—one to hold the Electric Operator in place, the other to remove bolts from the brackets.
- ③ Attach Nut Carrier and T-Nut to unit (see Fig. 3).
- ④ Install Threaded Rod Assembly through T-Nut and Nut Carrier (see Fig. 3). Make sure Threaded Rod Assembly is vertically plumb.
- ⑤ Install spring pin through pre-drilled hole at top of Threaded Rod.
- ⑥ Apply *entire tube* of lubricant (included) to T-Nut from top and bottom. As the threaded rod operates through the T-Nut, the lubricant will be spread onto the threaded rod as necessary.
Please Note: Be sure to apply the entire tube as described. If the lubricant is missing from your package, contact Draper, Inc.
- ⑦ Test operation.

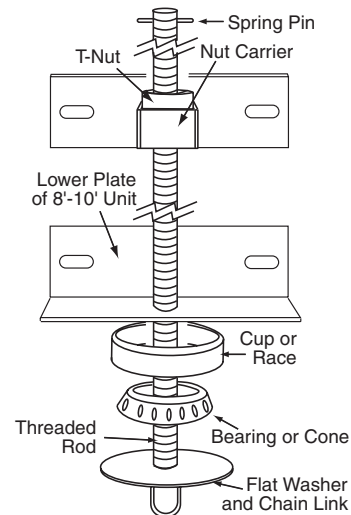

Figure 3

Please Note: See Page 2 for wiring diagrams and drawings of completed Height Adjusters.

Adjusting Limit Switches

- ① The upper (raised) position is pre-set at the factory.
- ② The upper plastic ring (A) controls the "down" position. Should this need to be adjusted, simply rotate clockwise for more travel and counterclockwise for less travel.

Please Note: The inner tube must be turned out three full turns ($\frac{1}{2}$ ") for safe, repeatable operation. It can be turned out more if required by application and if the upper cam is adjusted properly to prevent driving the inner tube against the full extend positive stop.

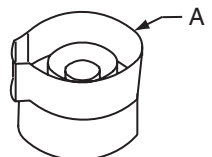

If you encounter any difficulties installing or servicing your Height Adjuster, call your dealer or Draper, Inc., Spiceland, Ind., (765) 987-7999; or fax (765) 987-7142.

Assembled Height Adjusters

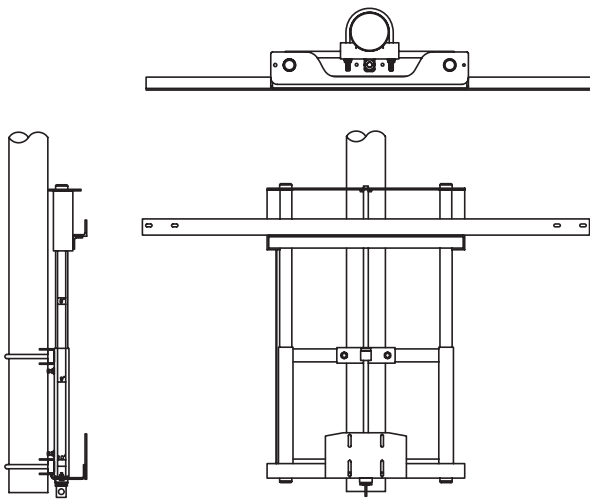

Rectangular Bank
Manual Height Adjuster

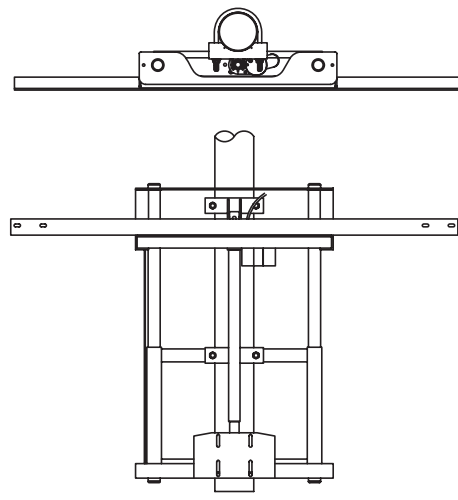

Rectangular Bank
Motorized Height Adjuster

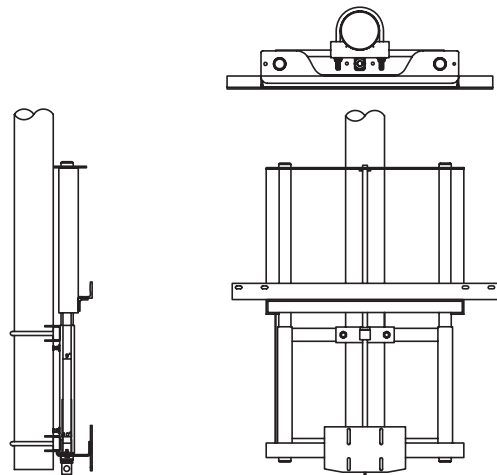

Fan Bank
Manual Height Adjuster

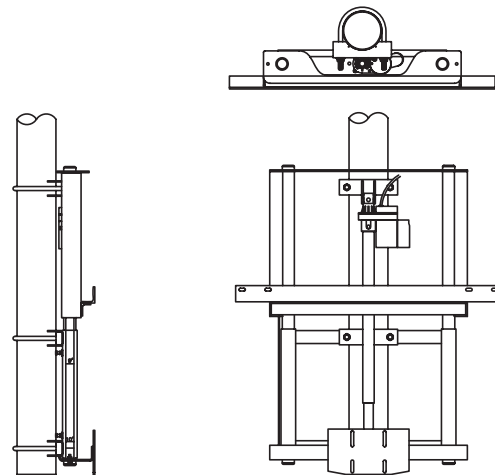

Fan Bank
Motorized Height Adjuster

Wiring Diagram

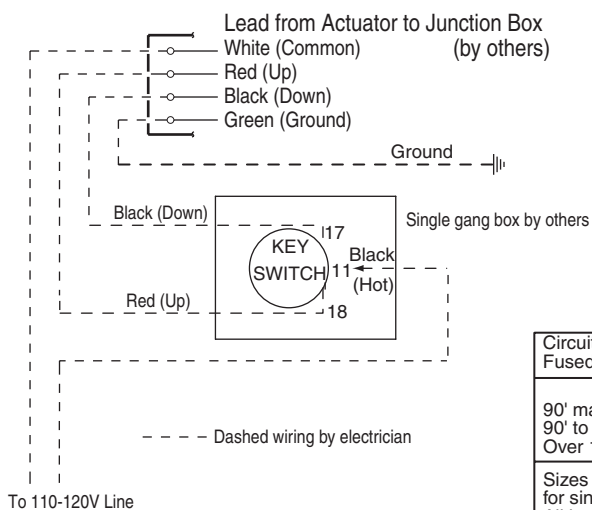

Circuit breaker rated amp. 20 amp.
Fused circuit rated amp. 20 amp.

Minimum Wire Size

90' maximum run. 12 ga.
90' to 140' run. 10 ga.
Over 140'. 8 ga.

Sizes of wall masonry boxes required for single and ganged key switches-- All boxes 2" deep and 4" high.

Draper Key Switch

