

# EZ Fold® 503136

Official 72" x 42" Rectangular  
Glass Basketball Backboard

by DRAPER

## Specifications—EZ Fold 503136

Official 72" x 42" Rectangular Glass  
Basketball Backboard

### Product Description

Backboard frame is a heavy, brushed aluminum extrusion for maximum durability. Extruded frame section of high tensile aluminum (6063-T5). Ends of the frame extrusions mitered and fitted with a flush, plated steel gusset type mounting bracket at upper corners and a plated L-style bracket at the lower corners. Upper corner mounting brackets incorporate keyhole slots for mounting the backboard to the support structure at standard mounting centers.

Goal mounting structure of a heavy, formed steel assembly, secured to the lower horizontal frame member to minimize stress on the glass section. Special steel sleeves at the goal mounting hole locations to secure rear structure to front mounting plate, forming a unitized assembly to minimize shock to the glass. Entire frame including goal mounting structure fitted with a shock absorbing neoprene material to cushion and protect the glass section.

Goal mount structure provided with two holes ( $\frac{7}{16}$ " and two studs ( $\frac{3}{8}$ "-16) to secure backboard and goal to an optional direct mount "goal brace" feature which relieves all stress and shock on the backboard conforming to the latest NCAA Rules (BR-73, D-5). Glass  $\frac{1}{2}$ " thick, fully tempered (heat-treated) glass section with uniform load and impact strength. Official white border and target area is "fired in" permanently on front side of glass section so that it cannot wear away.

Goal mounting holes (4) to be standard 5" (horizontal) x 4" (vertical) mounting centers.

### Lifetime Limited Warranty

Backboard shall be covered by a Lifetime Limited Warranty when installed on a Draper EZ Fold basketball backstop with Goal Brace or Direct Mount Height Adjuster. Contact Draper to request full warranty text.

### Optional 503253 Backboard Safety Padding

Padding to protect bottom and 15" up each side of the backboard to meet all NCAA, NFHS and professional requirements. Padding of a durable neutral gray, open cell foam material providing full 2" thickness from the bottom and sides of backboard frame. Front and back surfaces of backboard frame shall be further protected by a 1" thick lip extending  $\frac{3}{4}$ " up from bottom and sides of backboard.

Padding shall be permanently secured to the backboard frame by an easily applied high strength glue. Glue and brush provided. For use with all rectangular shaped glass backboards.

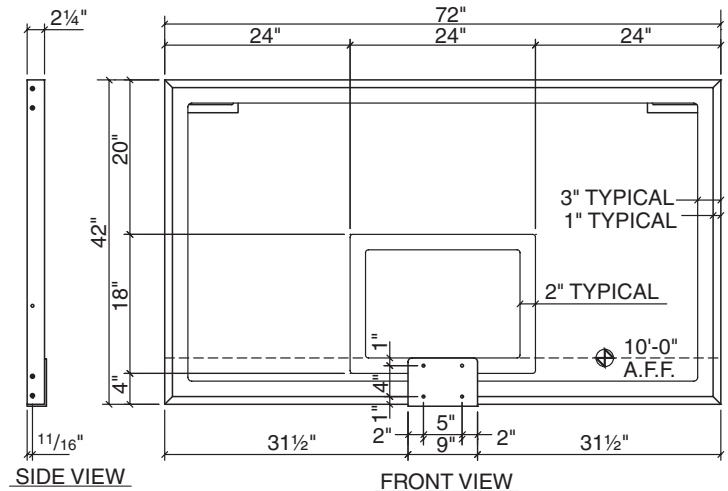
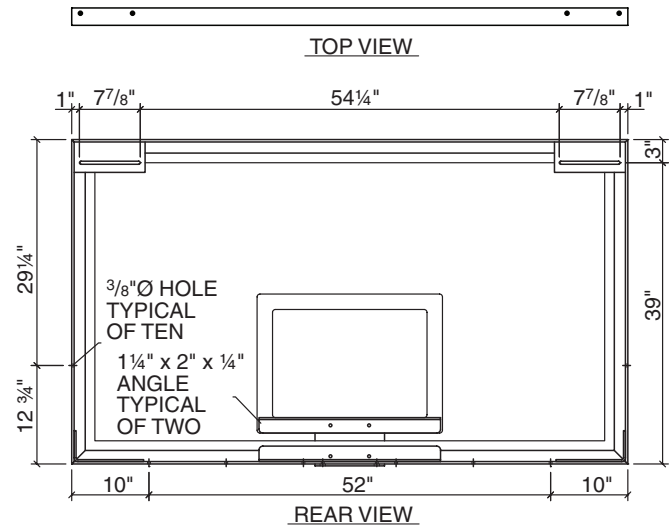

### Optional 5032XX Backboard Safety Padding

Molding process produces a super tough "skin" on the outside of the foam padding for long life. Pre-molded square corners for improved player safety. Molded-in steel track and bolt-on attachment system eliminate frustrating regluing or taping. Fits all official rectangular glass backboards.

Meets or exceeds all NCAA and High School Federation specifications. Available in NCAA-approved gray color. Also available in Dark/Royal Blue, Red/Scarlet, Navy, Marine/Columbia Blue, Kelly Green, Yellow/Gold, Forest Green, Orange, Purple, Black, and Maroon.

5-year warranty when installed indoors.

DRAPER®

411 S. Pearl St., Spiceland, IN 47385 USA ■ 765-987-7999  
www.draperinc.com ■ fax 765-987-7142

Copyright ©2010 Draper Inc. Form EZ-503136\_Sub10 Printed in U.S.A.

PROJECT: \_\_\_\_\_

ARCHITECT: \_\_\_\_\_

CONTRACTOR: \_\_\_\_\_

SUPPLIER: \_\_\_\_\_

DATE: \_\_\_\_\_ REVISED: \_\_\_\_\_