

First Team, Inc.

WallMonster Series

Installation Instructions

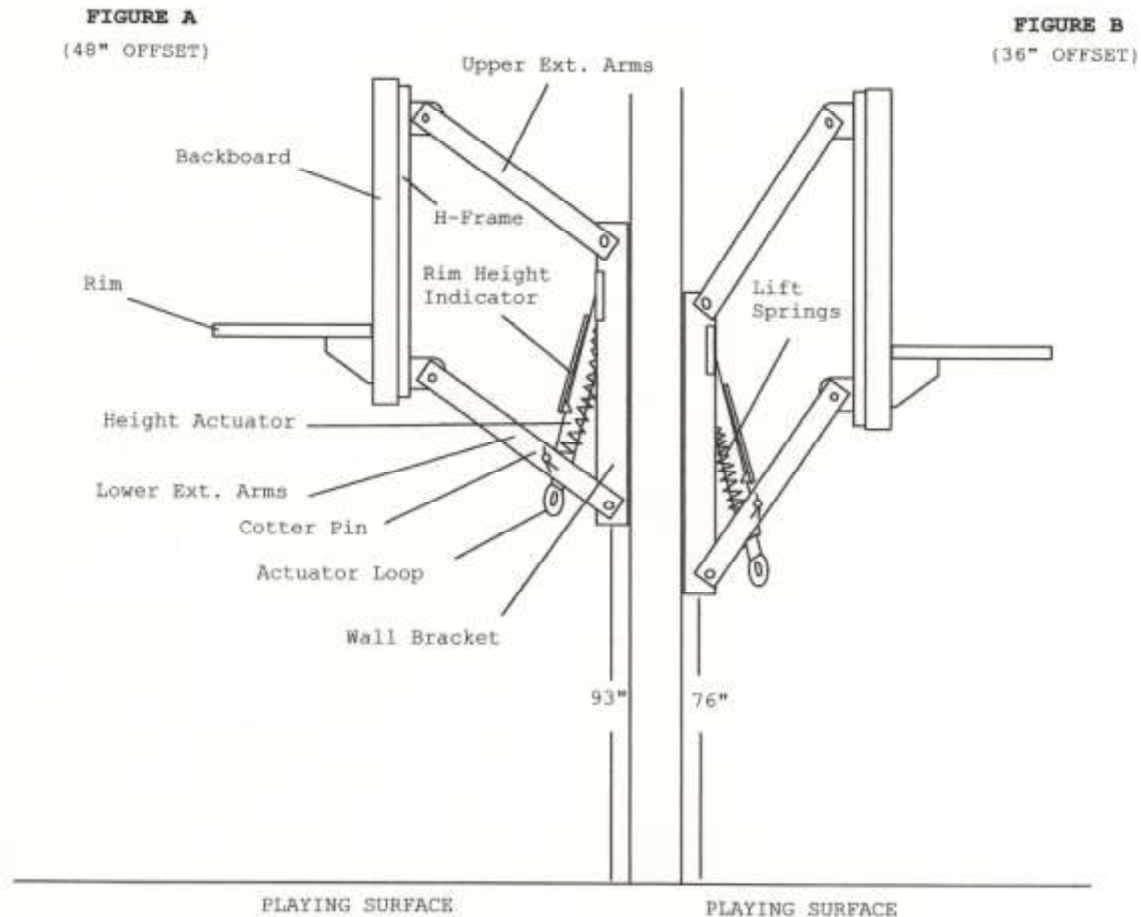

Bill of Materials

- A (1) Wall Bracket
- B (2) Upper Extension Arms
- C (1) Lower Extension Arm Assembly
- D (1) H-Frame Backboard Mount
- E (1) 5/8" x 25 1/2" Rod
- F (1) Rim Height Indicator
- G (1) Adjustment Crank Actuator
- H (1) Crank Handle
- I (4) Lift Springs
- J (1) Rim Height Stickers

- K (8) 5/8"x 3" Hex Bolt
- L (1) 5/8"x 5" Hex Bolt
- M (9) 5/8" Centerlock Nut
- N (8) 5/8" Nylon Flatwasher
- O (2) 1/16"x 1 1/2" Zinc Cotter Pin
- P (8) 3/8"x 1 1/4" Hex Bolt
- Q (8) 3/8" Flatwasher
- R (8) 3/8" Lockwasher
- S (8) 3/8" Hex

NOTE: Immediately unpack all components and cross check against bill of materials. Report any shortages to First Team customer service at 1-888-884-6677.

WARNING!! WARNING!! WARNING!! WARNING!! WARNING!!

Proper installation of this basketball structure requires adequate wall structure integrity. Consult with an architect or engineer if you are uncertain about whether your roof or wall is sufficient to support this structure adequately.

WARNING!! WARNING!! WARNING!! WARNING!! WARNING!!

Because each installation situation is unique, the anchoring hardware required to attach this system to your wall is not included with the unit. It is up to you to determine what hardware is suitable for your particular installation. It is advisable to consult with an architect or engineer if you are unsure about selecting the appropriate mounting hardware. Inadequate or improper installation of this basketball system can result in serious injury or death!

Read and understand all instructions completely before proceeding with installation.

WALLMONSTER WALL MOUNTING

First, refer to FIGURE A and B on page one of the assembly instructions. NOTE: The WallMonster may be installed either with a 36" or 48" OFFSET (distance from wall to backboard with rim at ten feet) Position the WALL BRACKET on your wall based on either FIGURE A or FIGURE B depending on the desired offset. Be sure WALL BRACKET is positioned correct distance above the playing surface. (refer to figure c for wall bracket top and bottom orientation)

Secure the WALLBRACKET to wall. **HARDWARE FOR SECURING ASSEMBLY TO WALL IS NOT SUPPLIED AND IS THE RESPONSIBILITY OF THE CUSTOMER.** While securing structure to wall it is important to place a level on the side of the WALL BRACKET to insure that the structure is level side to side before finishing attachment. Adjust as necessary until level.

NOTE: After you are satisfied that the structure is adequately fastened to the wall and that the wall is adequate to support the weight of this basketball system, you may proceed with the rest of the installation.

Locate the LOWER EXTENSION ARM assembly. Using Figure A (or Figure B) note that the LOWER EXTENSION ARM has 3 sets of holes drilled through it. The end with the holes closest to each other is the end that mounts to the WALL BRACKET.

With the LOWER EXTENSION ARM oriented properly, attach the LOWER EXTENSION ARM assembly to the WALL BRACKET using (2)

5/8"x 3" hex bolt, (2) 5/8" nylon flatwashers and (2) 5/8" centerlock nut. Place one nylon flatwasher on each side between the LOWER EXTENSION ARM and the WALL BRACKET support. The nylon washers eliminate paint wear and provide free movement at the pivot points. Remember, the nylon flatwashers go BETWEEN the extension arms and the side of the wall bracket.

Attach the UPPER EXTENSION ARMS using (2) 5/8"x 3" hex bolt, (2) 5/8" nylon flatwashers, and (2) 5/8" centerlock nuts. Remember, the nylon flatwashers go BETWEEN the extension arms and the side of the wall bracket.

Next, using (1) 5/8"x 5" hex bolt and (1) 5/8" centerlock nut, attach the ADJUSTMENT CRANK ACTUATOR to the ACTUATOR ATTACHEMENT EARS on the WALL BRACKET (see figure D). The yoked clevis of the adjustment crank should be cradled between the two welded tabs (ACTUATOR ATTACHMENT EARS) at the top of the WALL BRACKET support. Also attach the RIM HEIGHT INDICATOR at this time. The welded tube on the RIM HEIGHT INDICATOR fits between the yoked clevis on the adjustment crank. NOTE OF CLARIFICATION: The Adjustment Crank Actuator and Rim Height Indicator are both attached using the same 5/8"x 5" hex bolt mentioned above.

Using (1) 5/8"x 25 1/2" ROD provided and (2) 1/16"x 1 1/2" COTTER PIN attach the bottom end of the ADJUSTMENT CRANK ACTUATOR between the set of welded ears on the LOWER EXTENSION ARM as shown in Figure A & B. Secure 5/8" ROD in place using COTTER PINS.

Bolt the H-Frame to the extension arms using (4) 5/8"x 3" hex bolts, (4) 5/8" nylon washers and (4) 5/8" centerlock nuts. Remember to place the nylon washers between the extension arms and the sides of the H-Frame.

IF YOU PURCHASED A TEMPERED GLASS OR ACRYLIC (plexiglass) BACKBOARD you should find (4) grommets mounted in the four rim holes in the glass. If the grommets are not there, check the box, they may have fallen out during shipping. If the grommets are missing and cannot be located, DO NOT PROCEED WITH INSTALLATION, call First Team immediately for replacements, 1-888-884-6677. Grommets prevent glass/acrylic breakage when tightening rim bolts. NO GROMMETS ARE NECESSARY FOR NON-CLEAR BACKBOARDS.

Hang backboard on H-FRAME lining up the four holes at the top of the BACKBOARD frame with the four holes in the top of the H-FRAME.

Loosely attach BACKBOARD at these four points using (4) 3/8"x 1 1/4" hex bolts, flatwashers, lockwashers and hex nuts provided.

Loosely attach BACKBOARD to H-FRAME at the four points along the bottom of the backboard frame as well. Use (4) 3/8"x 1 1/4" hex bolts, flatwashers, lockwashers and hex nuts provided. Be sure the rim holes in the BACKBOARD and the rim holes in the H-FRAME are aligned so the rim bolts will be able to pass thru when attaching rim.

If you have a tempered glass or acrylic backboard, check once again to make sure all (4) grommets are in place in the backboard rim mounting holes. When you are satisfied with rim hole/H-Frame alignment, attach RIM following the instructions provided in the rim box. Then tighten the 3/8" hardware at both the top and bottom of the BACKBOARD frame.

Next, using a measuring tape and CRANK HANDLE crank unit until rim measures 10' from playing surface. Make a pencil mark on the side of the adjustment crank where the height indicator stops. Repeat this step for 9 1/2', 9', 8 1/2', 8', 7 1/2'. When finished peel and apply each rim height sticker lining up the pencil mark with mark provided on each respective sticker.

Next, using the CRANK HANDLE, crank unit upward so RIM reaches 10' mark. Then attach (2) lift springs on either side of the CRANK ADJUSTMENT ACTUATOR attaching one end first on the LIFT SPRING ATTACHMENT ROD (see figure c) and the other end of the LIFT SPRING on the 5/8"x 25 1/2" ROD mounted on the LOWER EXTENSION ARM (see figure A & B) You may find it helpful to loop a rope over the 5/8" ROD and attach it to one end of the spring. Then with the spring already attached to the LIFT SPRING ATTACHMENT ROD, pull down on the rope, extending the spring until it hooks itself over the 5/8" x 25 1/2" ROD. The welded ears on either side of the ACTUATOR ATTACHEMENT TUBE are designed to cradle two LIFT SPRINGS each.

Make sure all hardware has been tightened. If unit is difficult to crank you may have over tightened the bolts at the main pivot points, try loosening them slightly. Check over the unit periodically to make sure no hardware has loosened as the unit ages.

Installation of your First Team WallMonster Basketball System is complete!

TIP: Find a safe and handy location to store your crank handle. If you ever lose your crank handle, replacements can be purchased by calling First Team at 1-888-884-6677. We hope you enjoy your WallMonster basketball system.

WALL BRACKET
FIGURE C
Front View

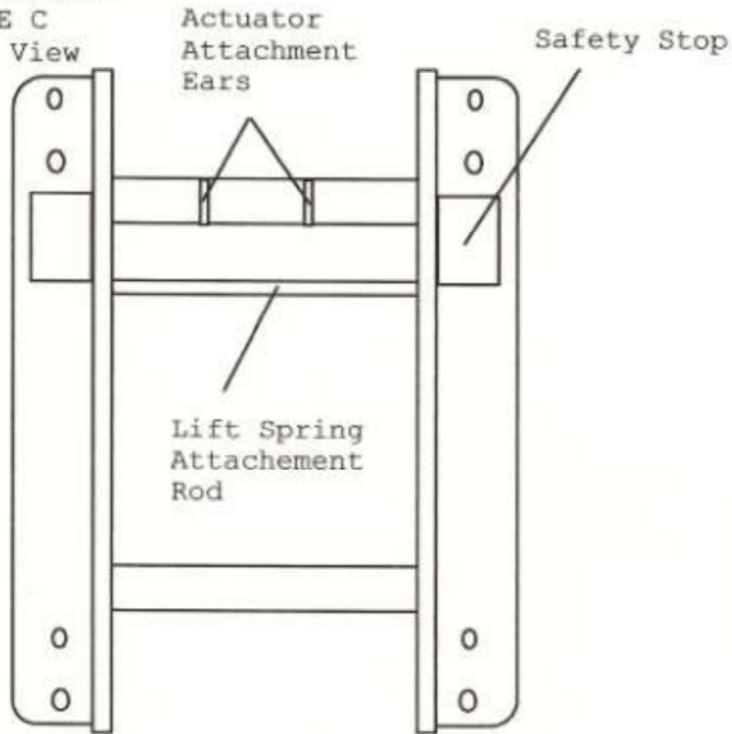

WALL BRACKET
FIGURE D
Side View

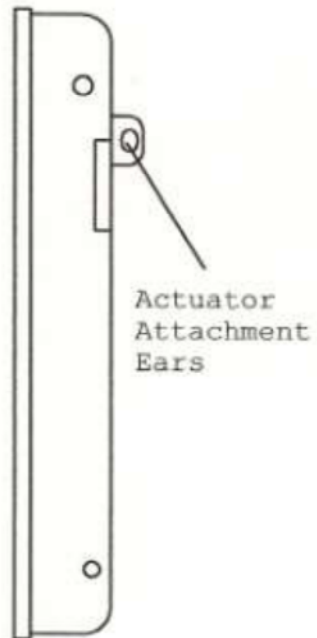

ACTUATOR
FIGURE E

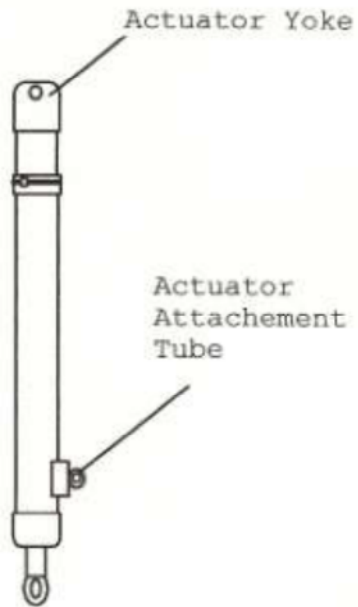

DIAGRAM OF PARTS

(NOTE: WALL BRACKET SHOWN IN FIGURES C&D)

