

First Team[®]

PowerHouse Series Assembly Instructions

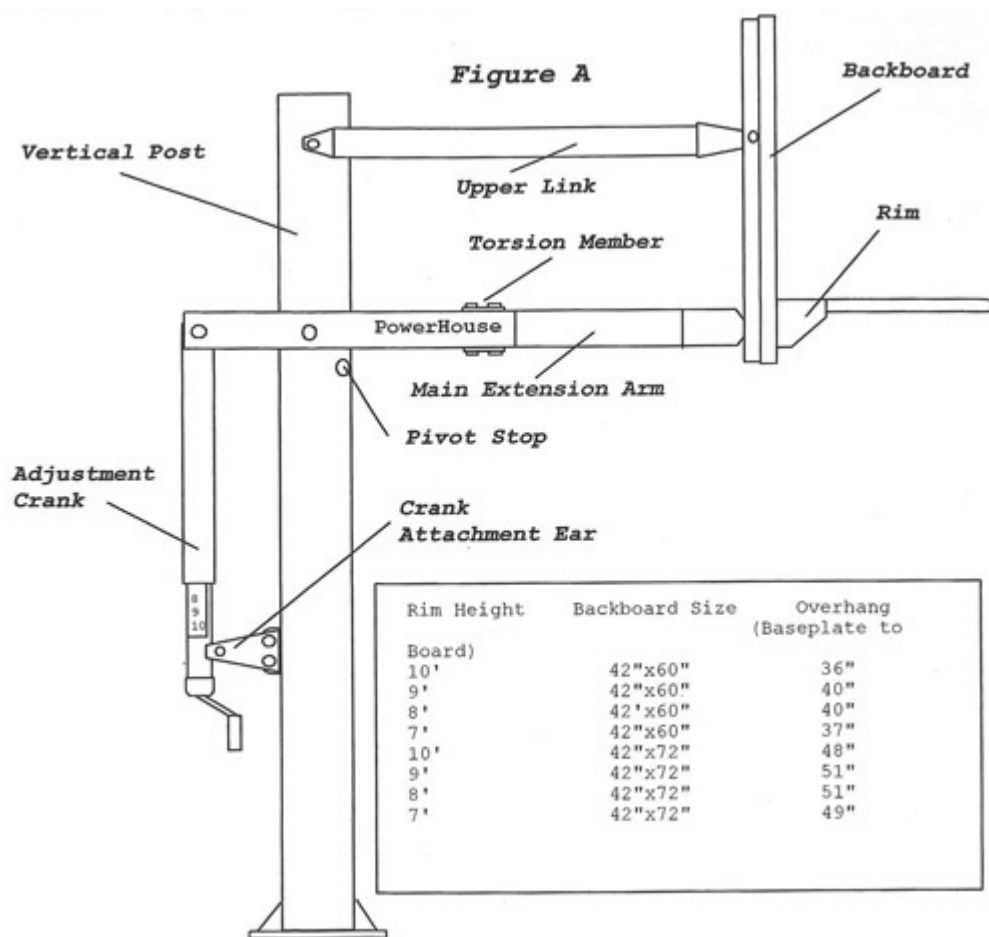

Bill of Materials

- | | | |
|------------------------|-----------------------------|----------------------------|
| (1) Rim | (1) Height Sticker | (2) 1/2" x 2" Hex Bolt |
| (1) Backboard | (1) Anchor Footing Template | (5) 1/2" x 5" Hex Bolt |
| (1) Vertical Post | (4) Anchor Footing Rebar | (1) 1/2" x 9 1/2" Hex Bolt |
| (2) Main Extension Arm | (4) 5/8" Anchor Bolt | (2) 1/2" x 13" Hex Bolt |
| (2) Upper Link | (12) 5/8" Hex Nut | (4) 1/2" Nylon Flatwasher |

(1) Torsion Member	(4) 5/8" Lockwasher	(16) 1/2" Centerlock Nut
(2) Crank Attachment Ear	(4) 1/2" x 1" Hex Bolt	
(1) Adjustment Crank	(2) 1/2" x 1 1/2" Hex Bolt	

NOTE: Immediately unpack all components and cross check against bill of materials. Report any shortages to First Team customer service at 1-888-884-6677.

1. Choose the proper location to dig for the concrete footing. Use the distance chart in figure A to help you make your decision. When choosing the exact position to dig, make sure to maximize the amount of playing surface while minimizing possible driveway obstruction.

2. Dig hole 48" deep and 24" square. Be sure to bell out the bottom 12" of the hole to give added stability to the footing. NOTE: If you live in an area where the frost line is below 48" it is advisable to dig to normal frost line. **Do not cheat on the hole size, it is imperative that the hole be a minimum of 48" deep and 24" square!**

3. Assemble the anchor kit as shown in Figure B. First thread a 5/8" hex nut 2 1/2" of the way on to each J-Bolt. Place the threaded end of each J-Bolt through the 4 holes located in the anchor template. Then thread a second 5/8" nut on to each J-Bolt until tight against the template, making sure to keep the J-Bolt hooks pointing in toward the center of the template.

4. For this step you will need: Level; Broomstick; Tape Measure. The 48" x 24" anchor footing will require a little over a 1/2 yard of 3000 psi concrete (32-34 60# sacks of premix concrete). More will be needed if you dig a larger hole. Make certain that you have enough concrete to finish the job. Allowing a portion to dry while you purchase more concrete will weaken the footing.

5. Mix the concrete according to the instructions on the bag. It is better to mix it slightly wet than too dry. Fill the hole full to ground level with as little time between batches as possible. Insert the broomstick in 3 or 4 different places and vibrate up and down to settle the concrete. Submerge the (4) anchor footing rebar pieces into the center of the hole spaced evenly in an 8"x 8" square pattern. Next set the anchor bolt assembly into the wet concrete, vibrate it as it goes in to make sure the concrete fills in around the J-Bolt hooks. Make sure the template is pressed firmly against the top of the wet concrete. Use the level to ensure that it is level in all directions. Additionally, the center line of the J-Bolts must be parallel with the edge of the playing surface. (See figure C)

STOP HERE! Allow footing to cure for seven days before proceeding.

6. Take off the top 5/8" nuts from the J-Bolts, remove the template and discard it.

7. Thread a second 5/8" nut on to each J-Bolt down against the nut embedded in the concrete.

8. Place the vertical post down over the footing making sure not to damage the J-Bolt threads. Using (4) 5/8" lockwashers and the final (4) 5/8" hex nuts, bolt down post finger tight with welded tabs facing away from playing surface.

9. Level the vertical post by adjusting the 5/8" nuts located underneath the base plate. Then tighten top nuts against the top side of the base plate.

10. Assemble main extension arm using the (2) Main Extension Arm halves and the Torsion Member. Bolt Torsion Member to Main Extension Arms using (4) 1/2"x 5" Hex Bolts and (4) 1/2" Centerlock Nuts as shown in Figure D. Leave all hardware finger tight for now!

11. Slide the main arm onto vertical post and attach to the lower pivot tube with a 1/2"x 13" hex bolt and a 1/2" centerlock nut. (See Figure A).

12. Bolt (2) Crank Attachment Ears to the welded tabs on backside of vertical post using (4) ½"x 1" Hex Bolts and (4) ½" Centerlock Nuts. NOTE: Crank Attachment Ears should be bolted to the OUTSIDE of welded tabs. (See Figure A)

13. Next attach the Adjustment Crank cylinder using (1) 1/2" x 13" hex bolt and (1) 1/2" x 5" hex bolt. Tighten each with a 1/2" Centerlock nut.

14. Attach Upper Links to vertical post with (1) ½"x 9 ½" hex bolt and a ½" Centerlock nut. Attention: It does not matter which end of the parallel link you attach to the vertical post.

15. Mount Backboard to Main Extension Arm. Along the bottom of your backboard you will find two welded mounting tabs. Raise Backboard into position and attach the Main Extension Arm to the welded tabs using (1) ½"x 1 ½" Hex Bolt, (1) ½" Nylon Flatwasher and (1) ½" Centerlock nut at each welded tab. **NOTE: THE 1/2" NYLON FLATWASHERS PROVIDED SHOULD BE SANDWICHED BETWEEN THE MAIN EXTENSION ARM AND THE BACKBOARD TABS TO AVOID METAL-TO-METAL CONTACT WHICH CAN CAUSE THE PAINT TO RUB OFF!!! ADDITIONALLY, MAKE SURE YOUR MAIN ARM IS ATTACHED TO THE OUTSIDE OF THE BACKBOARD TABS!!!**

16. Next, attach Upper Links to the Backboard. Using (1) ½" x 2" Hex Bolt, (1) ½" Nylon Flatwasher and (1) ½" Centerlock Nut attach each Upper Link to the INSIDE of steel perimeter backboard frame as shown in Figure A. **NOTE: THE ½" NYLON FLATWASHERS PROVIDED SHOULD BE SANDWICHED BETWEEN THE UPPER LINK AND THE STEEL BACKBOARD PERIMETER FRAME TO AVOID METAL-TO-METAL CONTACT WHICH CAN CAUSE THE PAINT TO RUB OFF!!! ADDITIONALLY, MAKE SURE YOUR UPPER LINKS ARE ATTACHED TO THE INSIDE OF THE BACKBOARD FRAME!!!!**

17. Mount the Rim to the Backboard assembly using the hardware supplied in the rim box. Use a level to make sure rim is level side to side before tightening nuts.

18. After everything is square, make sure all nuts have been tightened. However, do not overtighten, if unit is excessively difficult to crank up and down the main pivot nuts are probably too tight.

19. To apply the rim height sticker, first use a tape measure to crank rim up to exactly 10' from the playing surface. Use a pencil to make a mark on the steel casing just below the plastic outer tube. Crank unit to its lowest point. Then, peel and apply sticker to outside of the steel casing lining up the pencil mark with the 10' mark on the sticker. See Figure A for a diagram of a completed height sticker application.

Note: It is advisable to wait up to two weeks to allow the anchor footing to fully cure before aggressive play.

Figure B

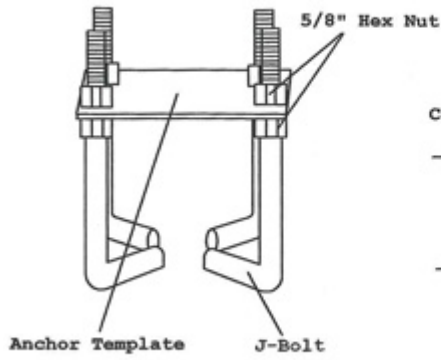
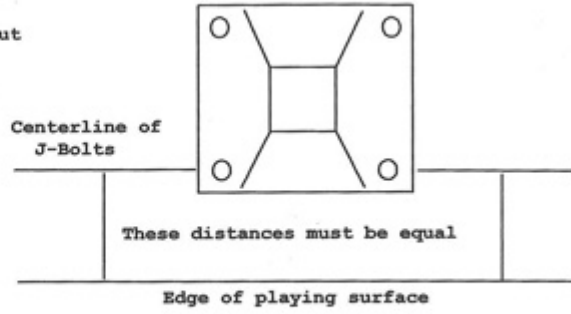
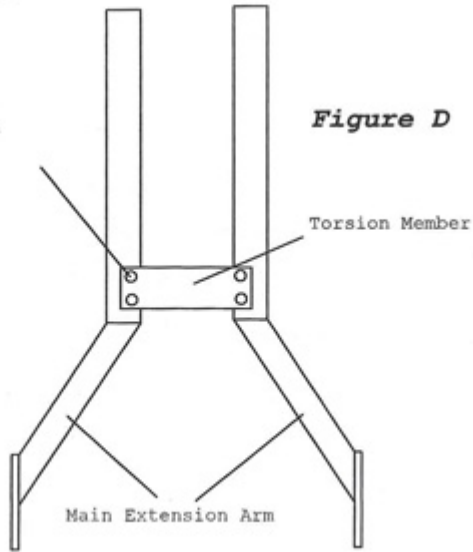

Figure C



Use (4) 1/2"x 5" Hex Bolts and (4) 1/2" Centerlock Nuts to secure Torsion Member to Main Extension Arms

Figure D



FIRST TEAM SPORTS, INC.
902 COREY ROAD
HUTCHINSON, KS 67501
TOLL FREE: 888-884-6677