

# Portable System Owners Manual

Customer Service Center

• N53 W24700 South Corporate Circle • Sussex, WI 53089 • U.S.A.

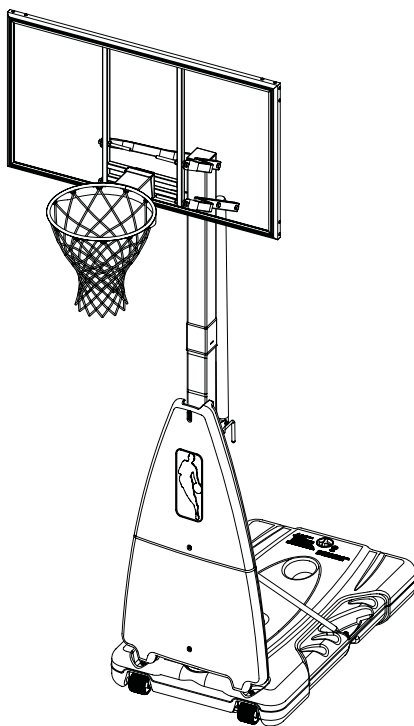

## Adult Assembly Required.

This manual, accompanied by sales receipt, should be saved and kept on hand as a convenient reference, as it contains important information about your model.



### WARNING!



READ AND UNDERSTAND  
OPERATOR'S MANUAL  
BEFORE USING THIS UNIT.

FAILURE TO FOLLOW  
OPERATING  
INSTRUCTIONS COULD  
RESULT IN INJURY OR  
DAMAGE TO PROPERTY.

Write Model Number From  
Box Here:

### REQUIRED TOOLS AND MATERIALS:



• 2 Capable Adults



• Tape Measure



• Wood Board (scrap)



• Sawhorse or Support  
Table



• Hammer



• Step Ladder 8 ft. (2.4m)



• Safety Glasses

• (2 each) Wrenches



1/2" 9/16" 3/4"

AND/OR

(2) Socket Wrenches and Sockets



1/2" 9/16" 3/4"

• Extension



• Phillips-Head Screwdriver



• Garden Hose or Sand

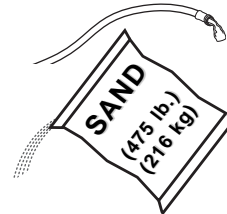

• Optional: Large & Small  
Adjustable Wrenches

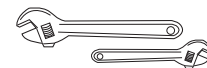

Toll-Free Customer Service Number for U.S.: 1-800-558-5234,

For Canada: 1-800-284-8339,

For Europe: 00 800 555 85234 (Sweden: 009 555 85234),

For Australia: 1800 632 792

Internet Address: [www.huffysports.com](http://www.huffysports.com)

[www.spalding.com](http://www.spalding.com)

# BEFORE YOU START

To ensure optimal playability of backboard system, a close tolerance fit between the elevator components and hardware is required. Test-fit large bolts into large holes of elevator tubes, backboard brackets, and triangle plates. Carefully rock them in a circular motion to ream out any excess paint from holes if necessary.

**NOTE: Not all items pictured are included with every model.**

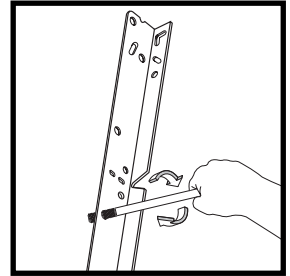
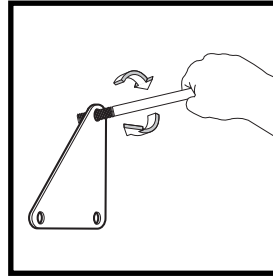
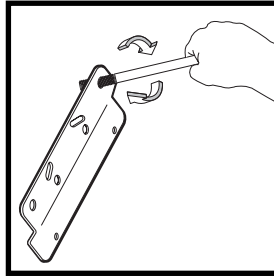
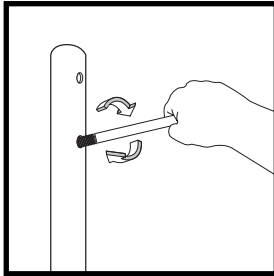

## HEIGHT ADJUSTMENT

Rotate crank handle to raise and lower backboard.

Do not over crank handle beyond the manufactured height indicator range of 7-1/2 - 10 feet. Damage may be caused to the screw jack's internal adjustment mechanism if adjusted over 10 or under 7-1/2 feet.

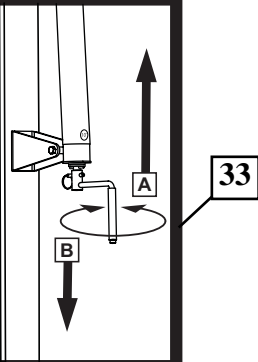

## MOVING SYSTEM

1. While holding pole, rotate basketball system forward until wheels engage with ground.
2. Move basketball system to desired location.
3. Carefully rotate basketball system upright.
4. Check system for stability.

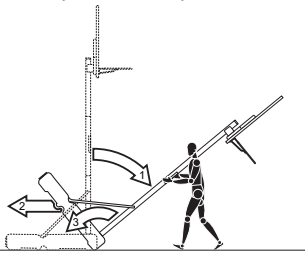

568090 11/06



### ! WARNING

Read and understand warnings listed below before using this product.

Failure to follow these warnings may result in serious injury and/or property damage.

Owner must ensure that all players know and follow these rules for safe operation of the system.

- DO NOT HANG on the rim or any part of the system including backboard, support braces or net.
- During play, especially when performing dunk type activities, keep player's face away from the backboard, rim and net. Serious injury could occur if teeth/face come in contact with backboard, rim or net.
- Do not slide, climb, shake or play on base and/or pole.
- After assembly is complete, fill system completely with water or sand. Never leave system in an upright position without filling base with weight, as system may tip over causing injuries.
- When adjusting height or moving system, keep hands and fingers away from moving parts.
- Do not allow children to move or adjust system.
- During play, do not wear jewelry (rings, watches, necklaces, etc.). Objects may entangle in net.
- Surface beneath the base must be smooth and free of gravel or other sharp objects. Punctures cause leakage and could cause system to tip over.
- Keep organic material away from pole base. Grass, litter, etc. could cause corrosion and/or deterioration.
- Check pole system for signs of corrosion (rust, pitting, chipping) and repaint with exterior enamel paint. If rust has penetrated through the steel anywhere, replace pole immediately.
- Check system before each use for proper ballast, loose hardware, excessive wear and signs of corrosion and repair before use.
- Check system before each use for instability.
- Do not use system during windy and/or severe weather conditions; system may tip over. Place system in the storage position and/or in an area protected from the wind and free from personal property and/or overhead wires.
- Never play on damaged equipment.
- When moving system, use caution to keep mechanism from shifting.
- Keep pole top covered with cap at all times.
- Do not allow water in tank to freeze. During sub-freezing weather add 2 gallons of non-toxic antifreeze, sand or empty tank completely and store. (Do not use salt.)
- While moving system, do not allow anyone to stand or sit on base or have added ballasting on base.
- Do not leave system unsupervised or play on system when wheels are engaged for moving.
- Use Caution when moving system across uneven surfaces. System may tip over.
- Use extreme caution if placing system on sloped surface. System may tip over more easily.
- See instruction manual for proper installation and maintenance.



By the U.S.A. 1460004201  
By Canada 1460204201



By the U.S.A. 1460004201





By the U.S.A. 1460004201  
By Canada 1460204201



By the U.S.A. 1460004201  
By Canada 1460204201

(EN) 558702 01/06

## NOTICE TO ASSEMBLERS

**Adult Assembly Required. Dispose of ALL packaging materials promptly. As with all products, periodically inspect for loose small parts.**

**Assembled unit MUST be filled with sand or water at ALL times.**

**ALL basketball systems, including those used for DISPLAYS, MUST be assembled and installed according to instructions. Failure to follow instructions could result in SERIOUS INJURY. It is NOT acceptable to devise a makeshift support system.**



# SAFETY INSTRUCTIONS



**FAILURE TO FOLLOW THESE SAFETY INSTRUCTIONS MAY RESULT IN SERIOUS INJURY OR PROPERTY DAMAGE AND WILL VOID WARRANTY.**

*Owner must ensure that all players know and follow these rules for safe operation of the system.*

To ensure safety, do not attempt to assemble this system without following the instructions carefully. Check entire box and inside all packing material for parts and/or additional instruction material. Before beginning assembly, read the instructions and identify parts using the hardware identifier and parts list in this document. Proper and complete assembly, use, and supervision are essential for proper operation and to reduce the risk of accident or injury. A high probability of serious injury exists if this system is not installed, maintained, and operated properly.

- If using a ladder during assembly, use extreme caution.
- Check base regularly for leakage. Slow leaks could cause the system to tip over unexpectedly
- Seat the pole sections properly (if applicable). Failure to do so could allow the pole sections to separate during play and/or during transport of the system.
- Climate, corrosion or misuse could result in system failure.
- If technical assistance is required, contact Customer Service.
- Minimum operational height is 6'-6" (1.98m) to the bottom of backboard.

*Most injuries are caused by misuse and/or not following instructions.*

*Use caution when using this unit.*

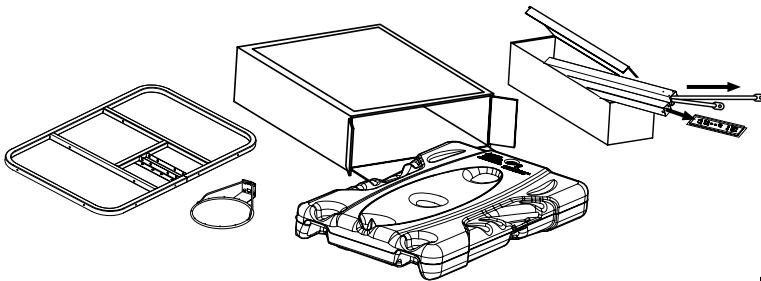

Questions or Missing Parts?

**DON'T go back to store!**

Call TOLL-FREE Customer Service Number listed on the front page!

### **IMPORTANT!**

**Remove all contents from boxes. Be sure to check inside pole sections, hardware and additional parts are packed inside.**

### **PRODUCT REGISTRATION:**

Please remember to complete your product registration form on-line at:  
[www.huffysports.com/customer\\_support/product\\_registration](http://www.huffysports.com/customer_support/product_registration).



## **WARNING!**



**IF YOUR SYSTEM IS EQUIPPED WITH AN ACRYLIC BACKBOARD, EXAMINE BACKBOARD FOR ANY DAMAGE THAT MAY HAVE OCCURRED DURING SHIPMENT. CRACKS IN THE BACKBOARD COULD RESULT IN SUDDEN BREAKAGE. IF BACKBOARD IS DAMAGED IN ANY WAY PRIOR TO OR AFTER ASSEMBLY, CALL TOLL-FREE NUMBER:  
U.S. 1-800-558-5234; CANADA: 1-800-284-8339; <http://www.huffysports.com>**

Get to know the basic parts of your basketball system...

FRONT

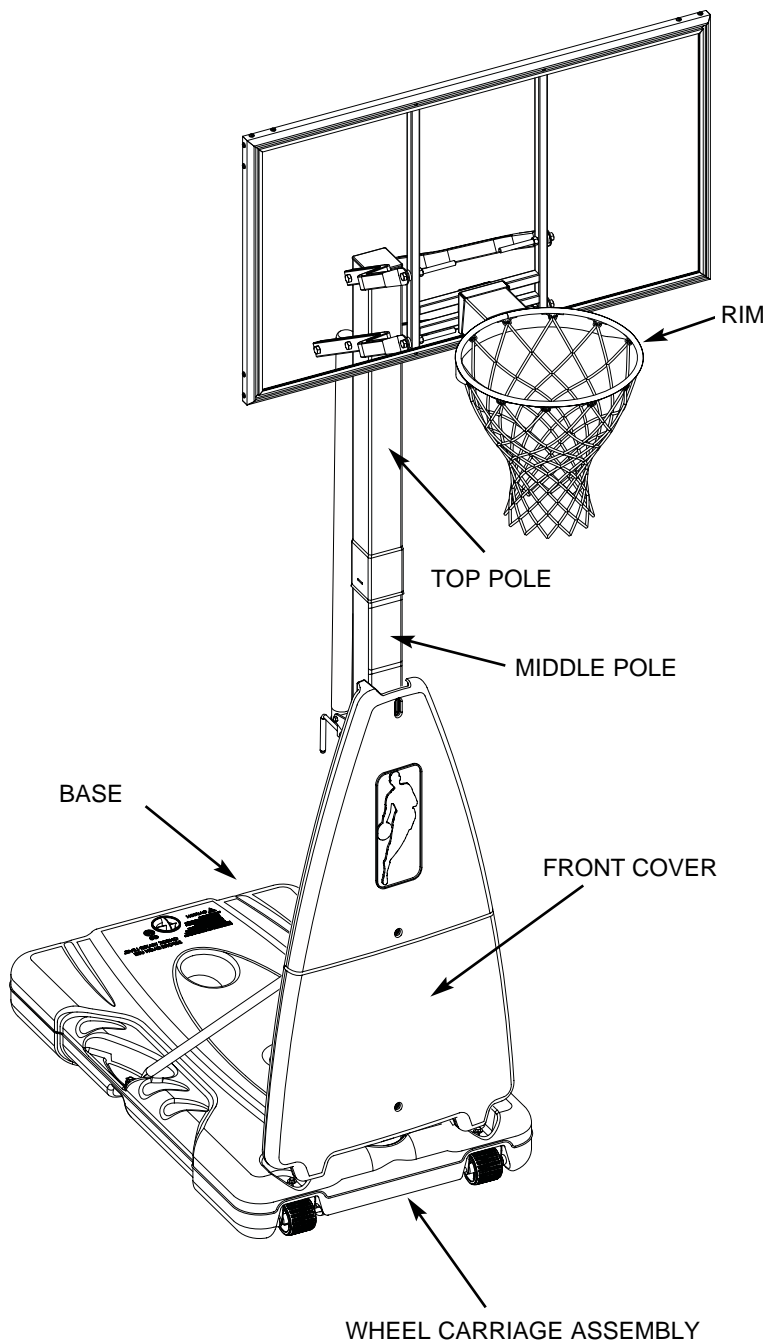

BACK

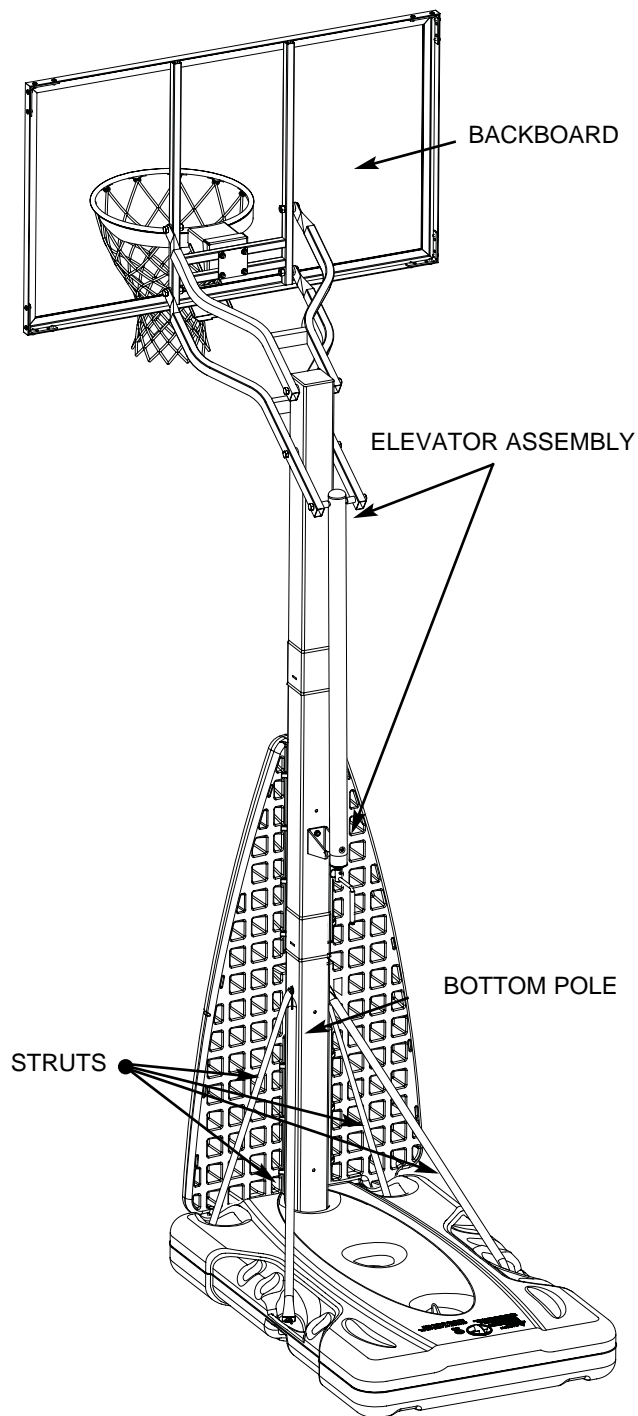

# PARTS LIST - See Hardware Identifier

<input checked="" type="checkbox"/> <u>Item</u>	<u>Qty.</u>	<u>Part No.</u>	<u>Description</u>		<input checked="" type="checkbox"/> <u>Item</u>	<u>Qty.</u>	<u>Part No.</u>	<u>Description</u>
<input type="checkbox"/> 1	1	600053	Tank		<input type="checkbox"/> 33	1	568090	Label, Height Adjustment and Moving
<input type="checkbox"/> 2	2	926410	Strut, Pole to Base				FR568090	Label, French
<input type="checkbox"/> 3	1	80034401	Screw Jack Assembly		<input type="checkbox"/> 34	1	908416	Plate, Washer, Rim
<input type="checkbox"/> 4	1	FR908559	Top Pole Section		<input type="checkbox"/> 35	1	908559	Elevator Tube, Upper - Short
<input type="checkbox"/> 5	1	FR908558	Middle Pole Section		<input type="checkbox"/> 36	2	202587	Spacer, .530 I.D. x 1" Long
<input type="checkbox"/> 6	1	FR918403	Bottom Pole Section		<input type="checkbox"/> 37	1	600068	Cover, Front
<input type="checkbox"/> 7	2	800332	Wheel Bracket		<input type="checkbox"/> 38	1	600052	Cap, Pole Top
<input type="checkbox"/> 8	2	600056	Wheel, 3.5"		<input type="checkbox"/> 39	2	220140	Screw, 1/4 x .375 Long
<input type="checkbox"/> 9	1	108306	Rod, Axle		<input type="checkbox"/> 40	2	600084	Foot
<input type="checkbox"/> 10	2	203099	Nut, Ny-lock, 5/16-18		<input type="checkbox"/> 41	1	700012	Cap, Base
<input type="checkbox"/> 11	1	600062	Cap, Cover, Height Indicator		<input type="checkbox"/> 42	1	206989	Reinforcement Bracket
<input type="checkbox"/> 12	1	207409	Bolt, Hex Head, 5/16-18 x 5.25 Long		<input type="checkbox"/> 43	1		Net
<input type="checkbox"/> 13	2	206938	Pushnut, 7/16 Shaft Diameter		<input type="checkbox"/> 44	3	200516	Bolt Cap
<input type="checkbox"/> 14	11	203100	Hex Flange Nut 5/16-18		<input type="checkbox"/> 45	2	918524	Strut, Pole to Base
<input type="checkbox"/> 15	1	918415	Bracket, Pole Mount		<input type="checkbox"/> 46	4	201611	Bolt, Hex Flange, 5/16-18 x 3 Long
<input type="checkbox"/> 16	2	204846	Carriage Bolt, 5/16-18 x 4.5 Long		<input type="checkbox"/> 47	1	800395	Pin, 2.25" Long
<input type="checkbox"/> 17	1	600058	Cover, Upper Tube		<input type="checkbox"/> 48	1	202822	Eyebolt, 3/8-16 x 3.75
<input type="checkbox"/> 18	6	203153	Bolt, Hex Head, 5/16-18 x .75 Long		<input type="checkbox"/> 49	2	201976	Bolt, 1/4-20 x 1.5" Long
<input type="checkbox"/> 19	1	108181	Plate, Pole Mounting		<input type="checkbox"/> 50	2	240027	Nut, Ny-lock, 1/4-20
<input type="checkbox"/> 20	1	201518	Bolt, Hex Head, 5/16-18 x 2.75 Long		<input type="checkbox"/> 51	1	20252301	Spacer, Rim, 5.32" Long
<input type="checkbox"/> 21	1	700009	Handle, Elevator Assembly		<input type="checkbox"/> 52	2	202603	Washer, Nylon, .520 I.D. x 1.25" Long
<input type="checkbox"/> 22	1	202528	Pin, Actuator Assembly		<input type="checkbox"/> 53	1	908477	Back Plate
<input type="checkbox"/> 23	4	206665	Bolt, Hex Head, 1/2-13 x 2 Long		<input type="checkbox"/> 54	1	908476	Rim Weldment
<input type="checkbox"/> 24	12	203218	Washer, Flat, 5/16		<input type="checkbox"/> 55	1	203439	Bolt, Hex Head, 3/8-16 x 6" Long
<input type="checkbox"/> 25	2	203679	Bolt, Hex Head, 3/8-16 x 2 Long		<input type="checkbox"/> 56	1	203063	Nut, Ny-lock, 3/8-16
<input type="checkbox"/> 26	2*	203104	Bolt, Hex Flange, 5/16-18 x 2 Long		<input type="checkbox"/> 57	2	203232	Washer, Flat, 3/8 x .75 O.D.
<input type="checkbox"/> 27	3	207408	Carriage Bolt, 5/16-18 x 4.75 Long		<input type="checkbox"/> 58	1	200484	Spring, Compression
<input type="checkbox"/> 28	1	91808603	Cover Plate, Rim		<input type="checkbox"/> 59	1	202601	Washer, .660 I.D., 1.33 O.D.
<input type="checkbox"/> 29	3	205678	Bolt, Hex Head, 1/2-13 x 7 Long		<input type="checkbox"/> 60	1	203795	Nut, Skirted, 3/8-16
<input type="checkbox"/> 30	8	201651	Spacer, Plastic, .530 I.D. x .25 Long					
<input type="checkbox"/> 31	7	206340	Lock Nut, Hex 1/2-13					
<input type="checkbox"/> 32	1	908561	Elevator Tube, Lower - Long					

\* YOU MAY HAVE EXTRA PARTS WITH THIS MODEL.



## NOTE

**Hardware kit is designed for more than one style of basketball system. Not all hardware will be used.**

**HARDWARE IDENTIFIER (BOLTS & SCREWS)**

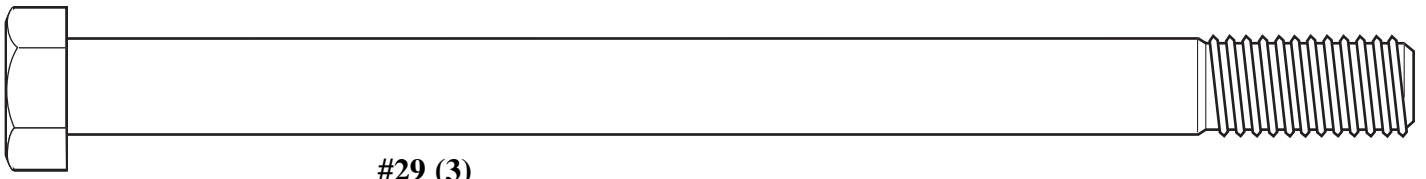

**#29 (3)**

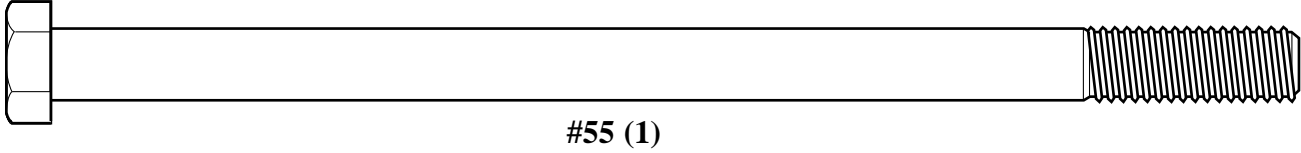

**#55 (1)**

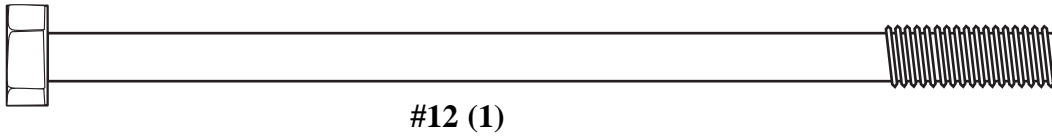

**#12 (1)**

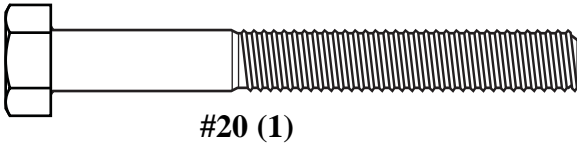

**#20 (1)**

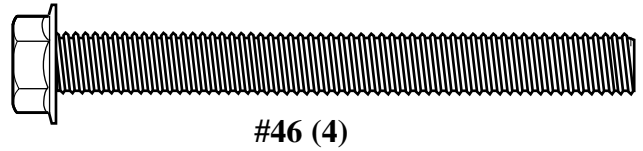

**#46 (4)**

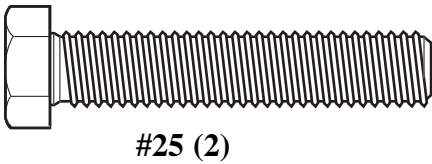

**#25 (2)**

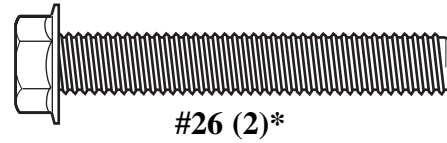

**#26 (2)\***

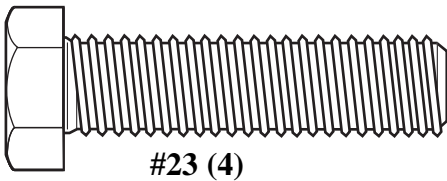

**#23 (4)**

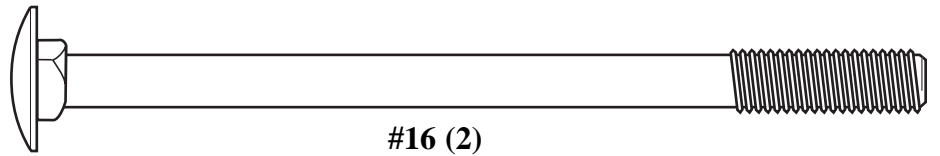

**#16 (2)**

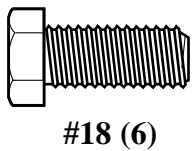

**#18 (6)**

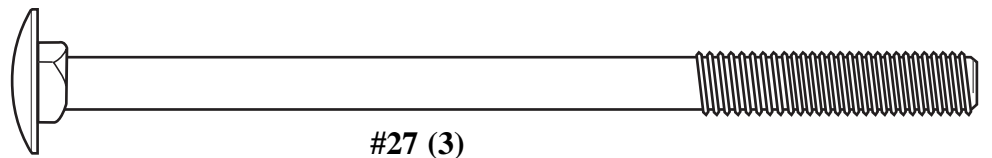

**#27 (3)**

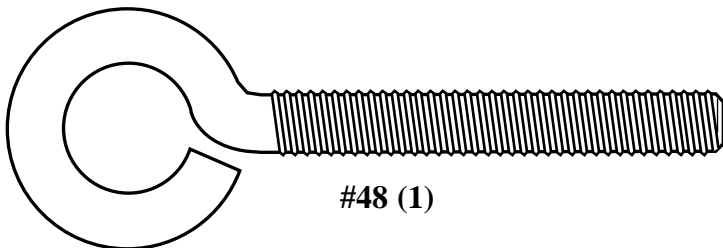

**#48 (1)**

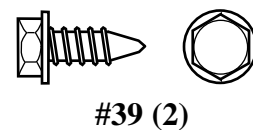

**#39 (2)**

\* You may have extra parts with this model.

**HARDWARE IDENTIFIER (NUTS & WASHERS)**

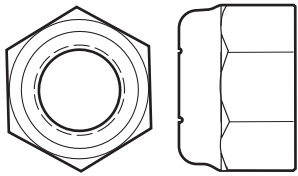

#31 (7)

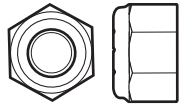

#50 (2)

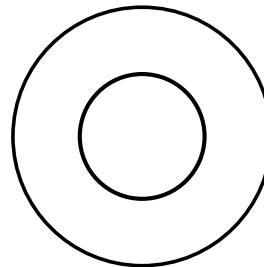

#59 (1)

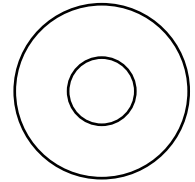

#24 (12)

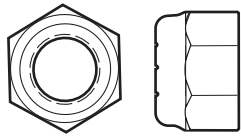

#56 (1)

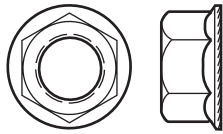

#14 (11)

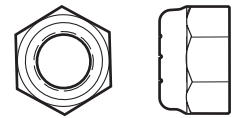

#10 (2)

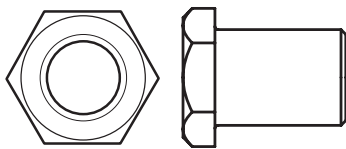

#60 (1)

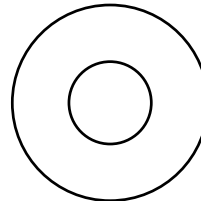

#52 (2)

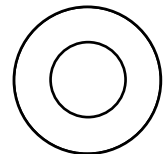

#57 (2)

**HARDWARE IDENTIFIER (PLASTIC SPACERS & CAPS, METAL SPACERS & OTHER)**

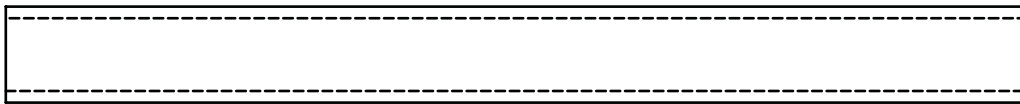

#51 (3)

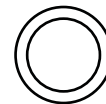

#44 (3)

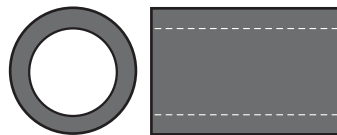

#36 (2)

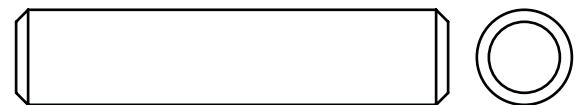

#47 (1)

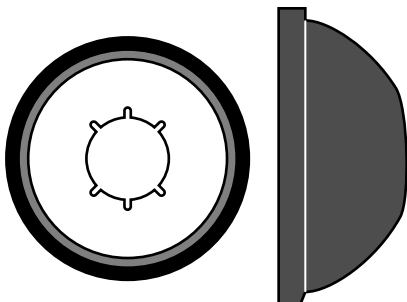

#13 (2)

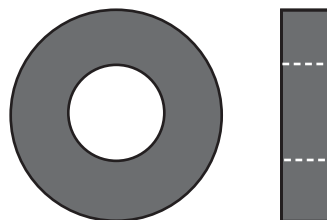

#30 (8)

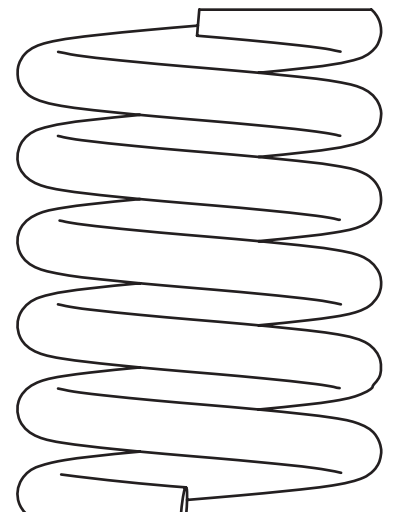

#58 (1)

# SECTION A: ASSEMBLE THE BASE

This is what your system will look like when you've finished this section.

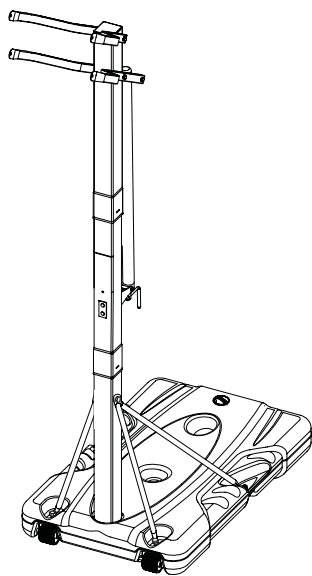

## TOOLS REQUIRED FOR THIS SECTION

(2) Wrenches



9/16", 1/2"

AND/OR

(2) Socket Wrenches and Sockets

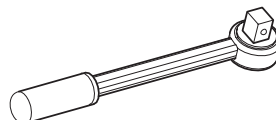

1/2"



9/16"

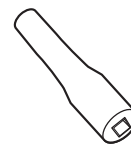

Extension

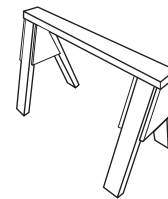

Sawhorse or support table

- Complete wheel assembly as shown in Figure A. Secure wheel bracket (7) and wheel assembly (Fig. A.) to the tank (1) with a bolts (18) and washers (24).

**Fig. A.**

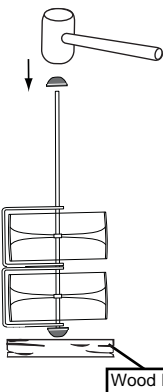

### NOTE:

#### TO INSTALL SECOND PUSHNUT:

- Assemble Pushnut, Wheels, Axle, And Wheel Bracket As Shown.
- Support Pushnut/Axle From The End With A Block Of Wood To Install The Second Pushnut Onto The Axle.

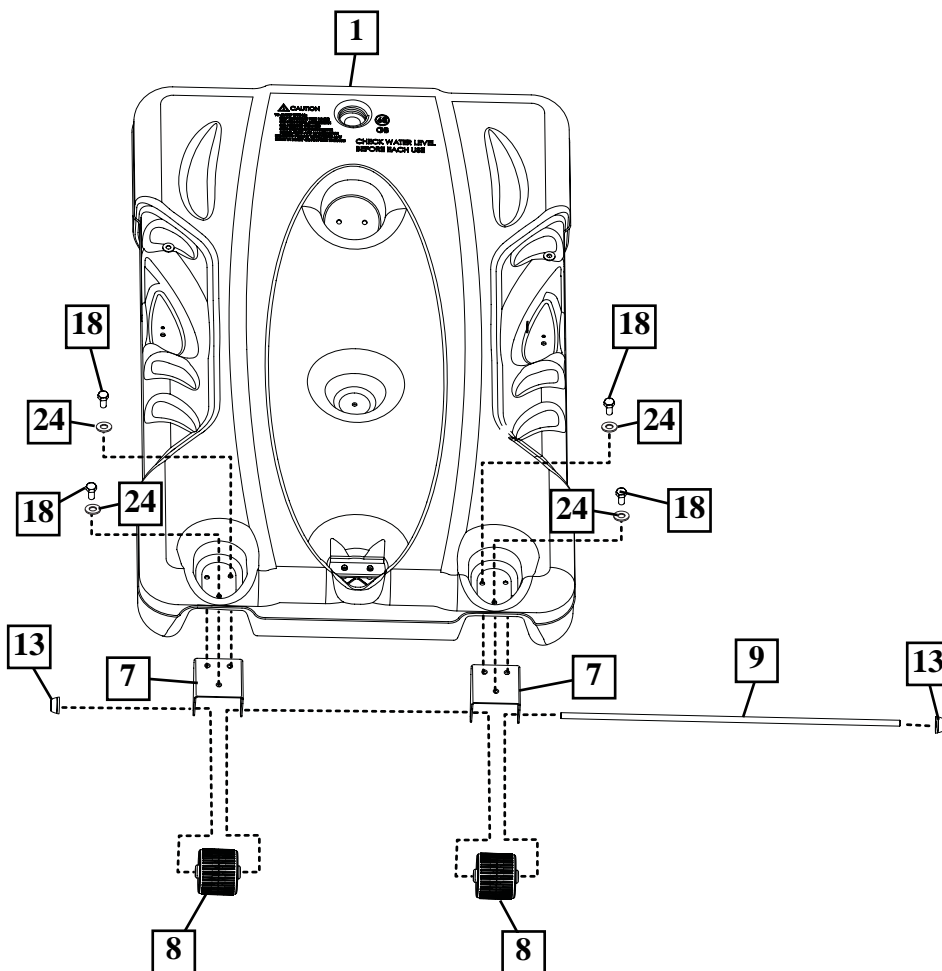

- 2.** Correctly identify each pole section. Poles have an identification sticker that will be used as a reference point in the next step.

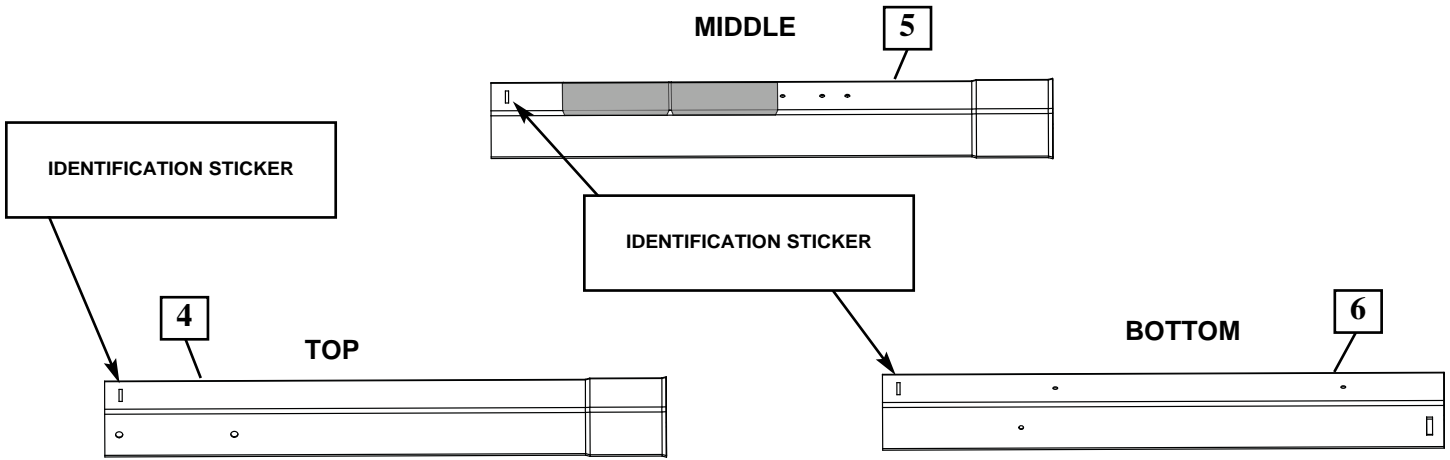

- 3.** Bounce middle pole section (5) into top section (4) using a wood scrap as shown until the top pole no longer moves toward the pole identification sticker on the middle pole.

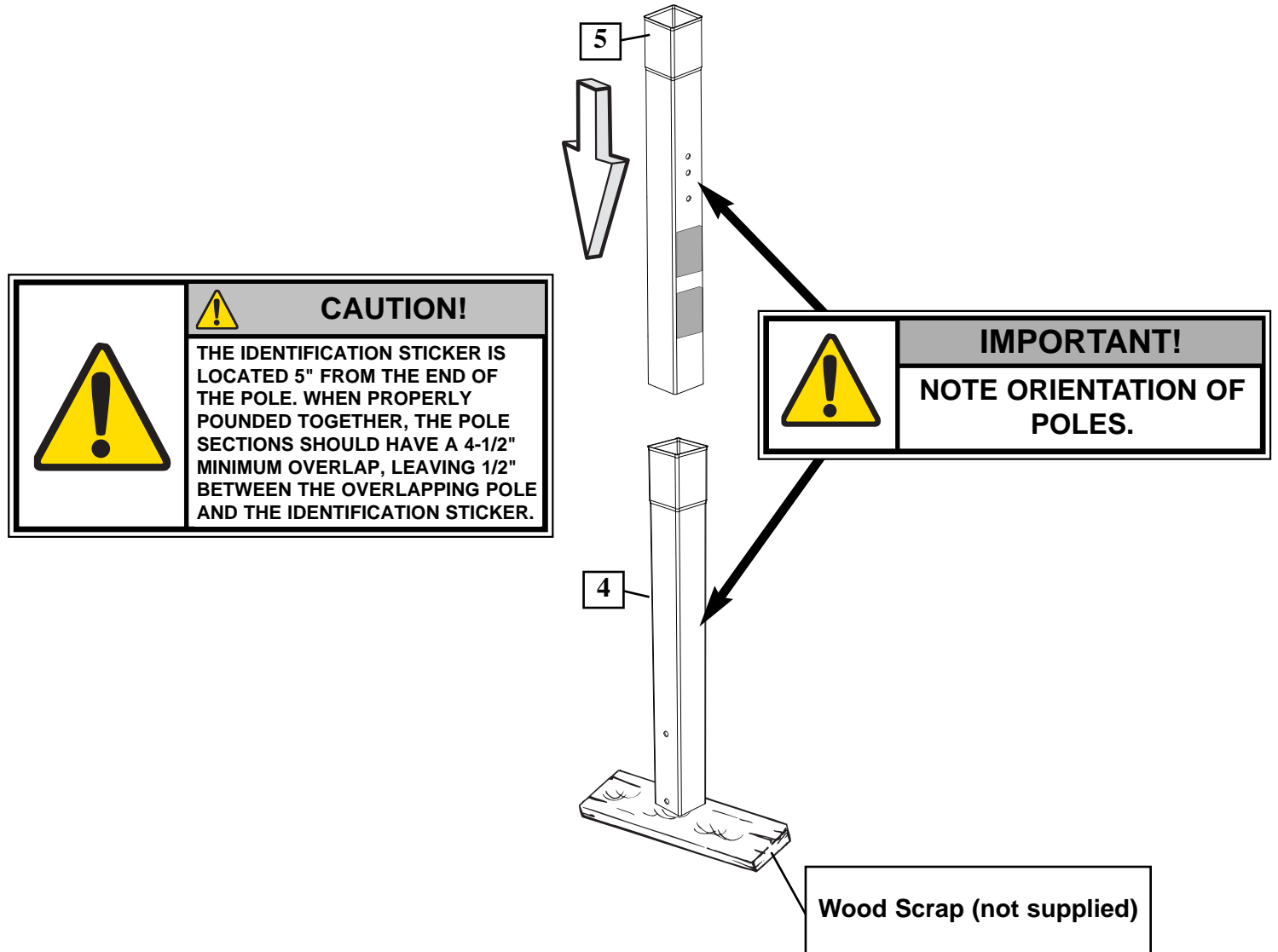

- 4.** Bounce top and middle pole assembly (4 and 5) onto bottom pole section (6) using a wood scrap as shown. Bounce until the top and middle pole assembly no longer moves toward the pole identification mark on the bottom pole.



**IMPORTANT!**

**NOTE ORIENTATION.**

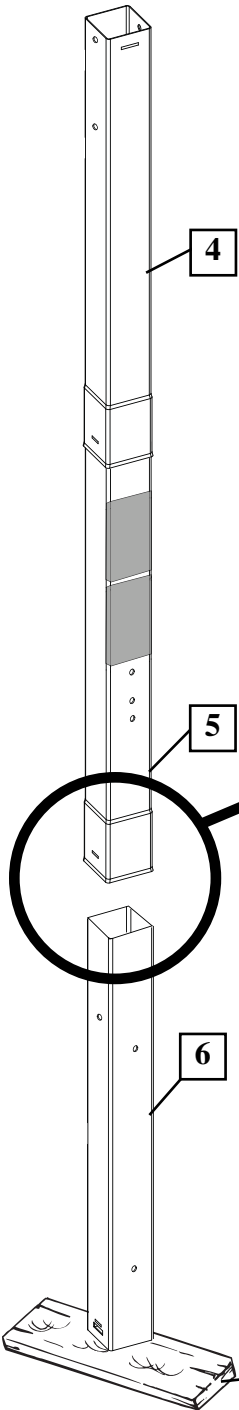
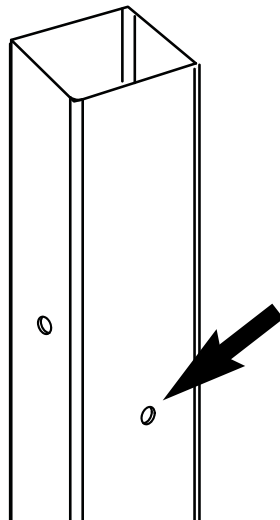
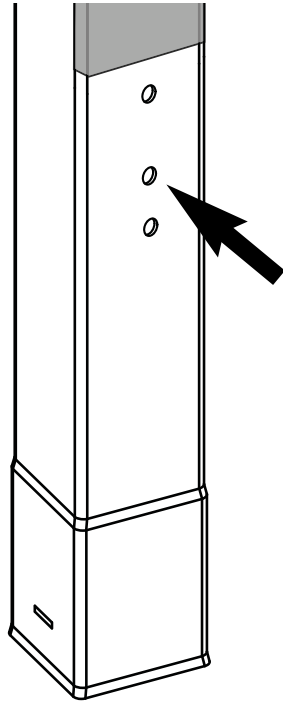

**Wood Scrap  
(not supplied)**

- 5.** Attach pole assembly to tank (1) as shown. Secure pole assembly to tank using bolts (25) and pole mounting plate (19) as shown.



**WARNING!**



**TWO CAPABLE ADULTS  
REQUIRED FOR THIS  
PROCEDURE. FAILURE TO  
FOLLOW THIS WARNING COULD  
RESULT IN SERIOUS INJURY  
AND/OR PROPERTY DAMAGE.**

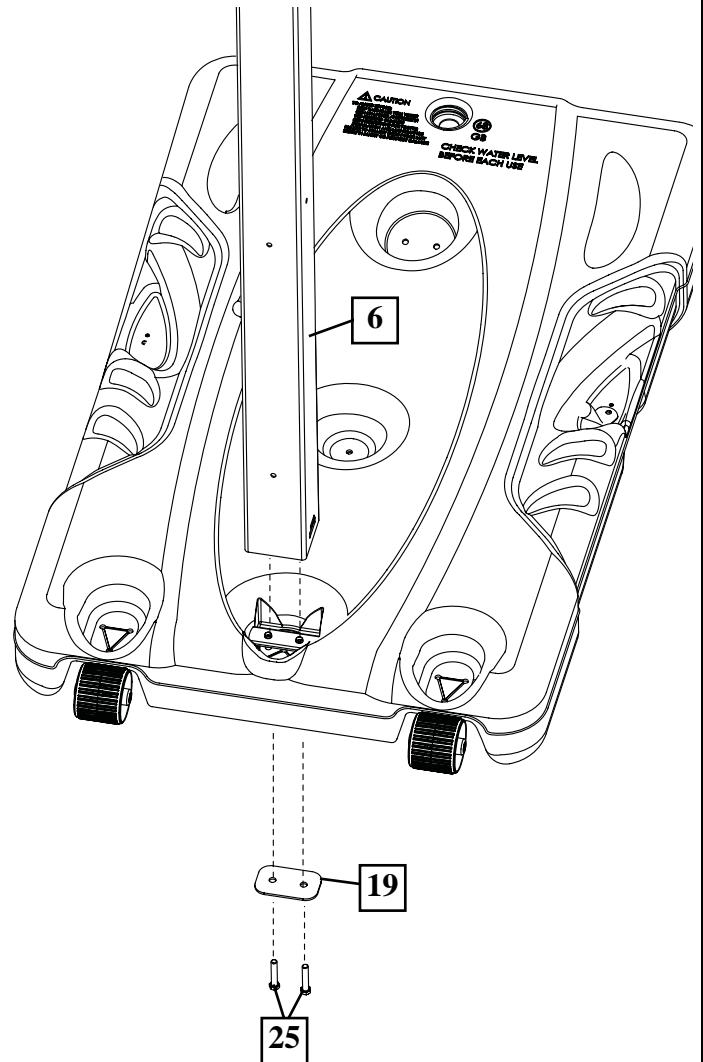

6. Secure front tank struts (45) to tank (1) and wheel assemblies as shown.

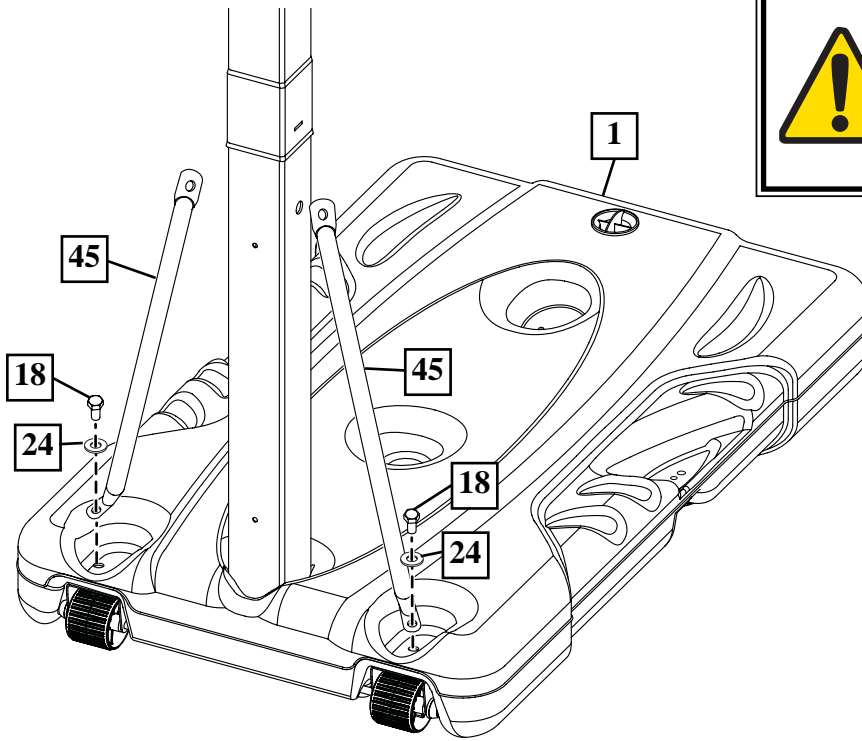

**IMPORTANT!**

**DO NOT TIGHTEN COMPLETELY.**

7. Secure tank struts (2, 45) to pole as shown.

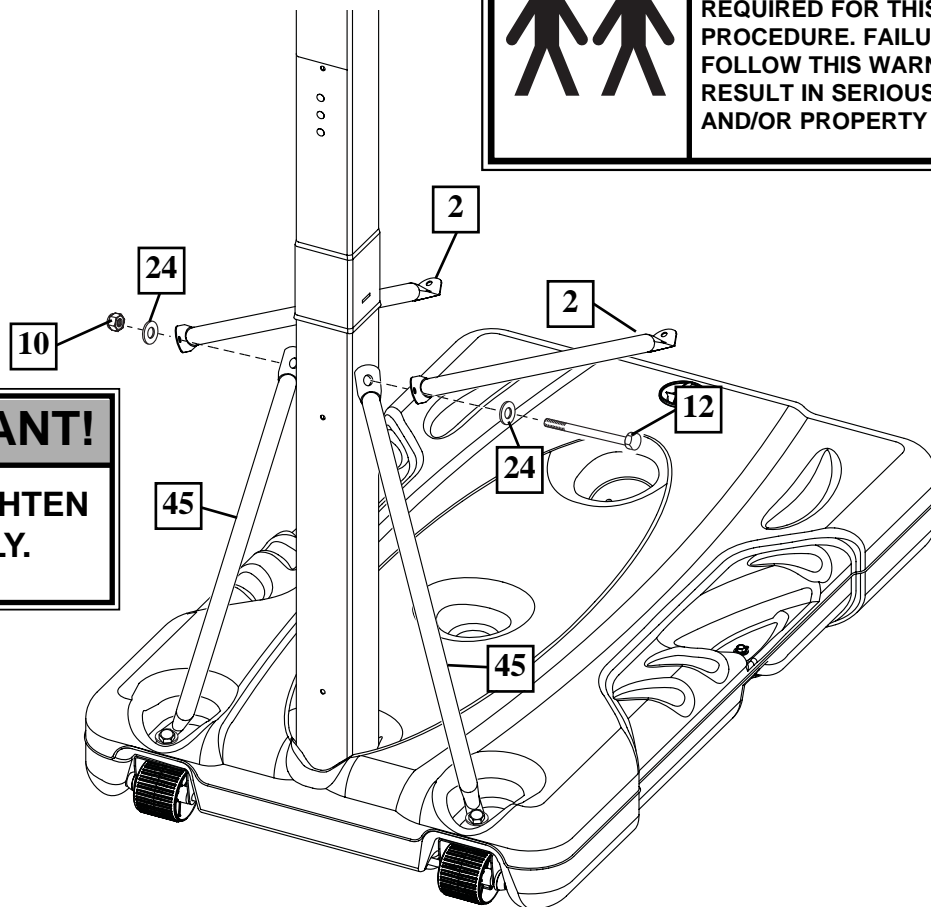

**WARNING!**

**TWO CAPABLE ADULTS REQUIRED FOR THIS PROCEDURE. FAILURE TO FOLLOW THIS WARNING COULD RESULT IN SERIOUS INJURY AND/OR PROPERTY DAMAGE.**



**IMPORTANT!**

**DO NOT TIGHTEN COMPLETELY.**

- 8.** Rotate non-secured ends of the rear tank struts (2) outward to mounting holes in tank as shown. Secure non-secured ends of tank struts (2) to tank as shown. Repeat for opposite side.

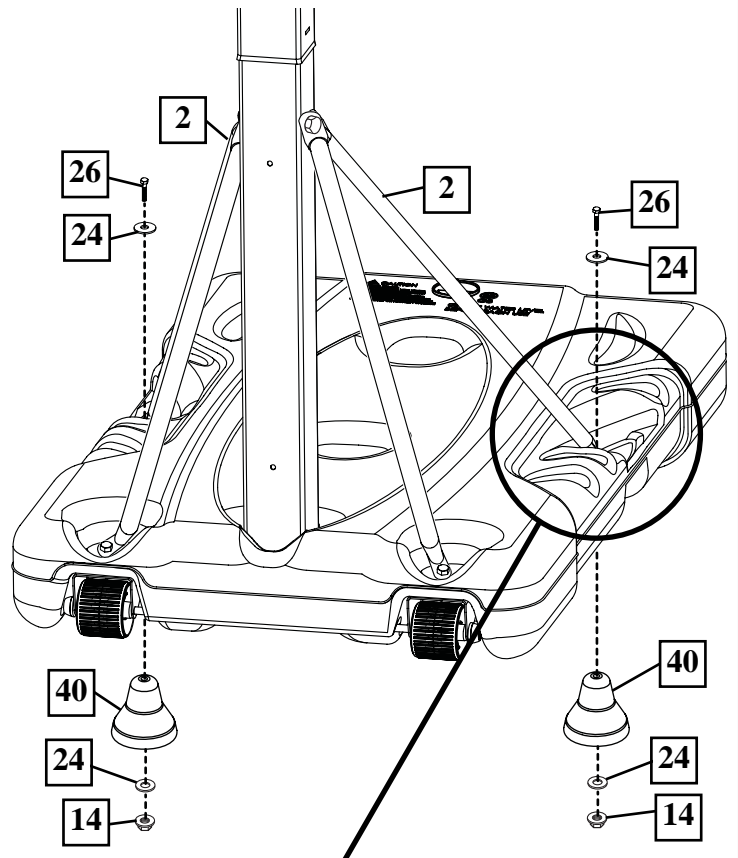
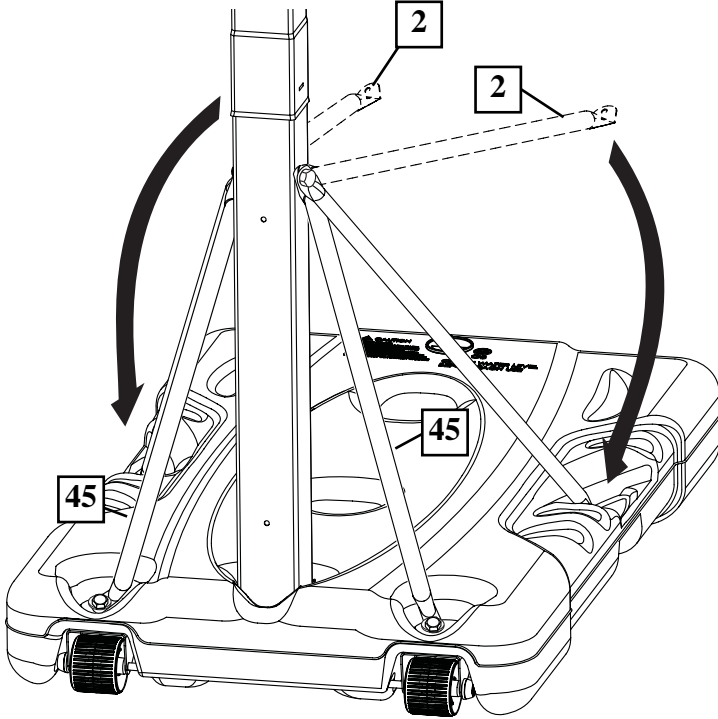

	<p><b>⚠ WARNING!</b></p>
	<p>TWO CAPABLE ADULTS REQUIRED FOR THIS PROCEDURE. FAILURE TO FOLLOW THIS WARNING COULD RESULT IN SERIOUS INJURY AND/OR PROPERTY DAMAGE.</p>

	<p><b>IMPORTANT!</b></p>
	<p>Struts <b>MUST</b> be attached to the base through the <b>REAR</b> holes.</p>

	<p><b>IMPORTANT!</b></p>
	<p>DO NOT TIGHTEN COMPLETELY.</p>

- 9.** Install pole mount bracket (15) and reinforcement bracket (42) with carriage bolts (16) as shown. Tighten flange nuts (14) completely.

	<p><b>IMPORTANT!</b></p>
	<p>DO NOT OVER TIGHTEN!</p>

	<p><b>IMPORTANT!</b></p>
	<p>TIGHTEN ALL HARDWARE FROM STEPS 6-9 AFTER THIS ASSEMBLY IS COMPLETED.</p>

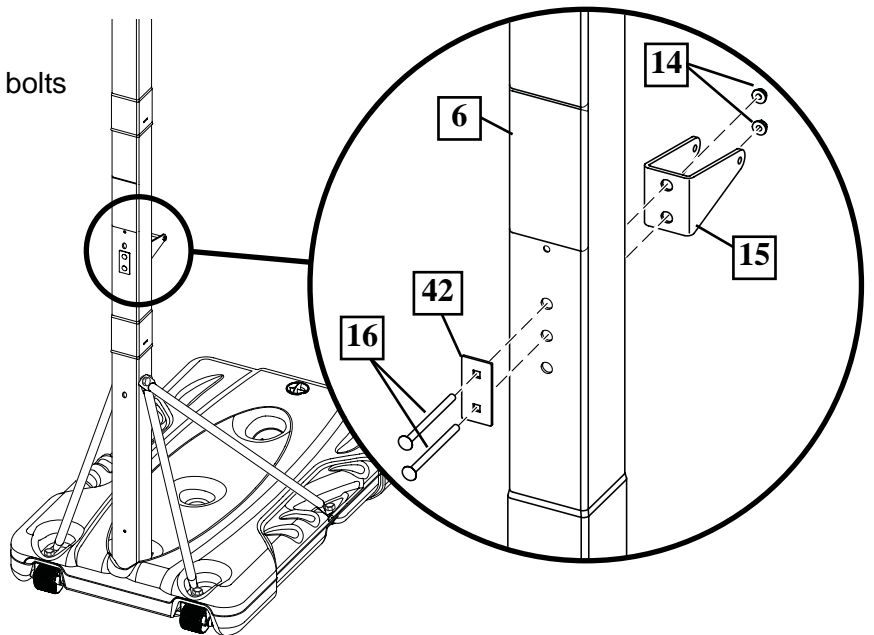

- 10.** Securely rest the assembly on sawhorse. Identify elevator tubes (32 and 35).

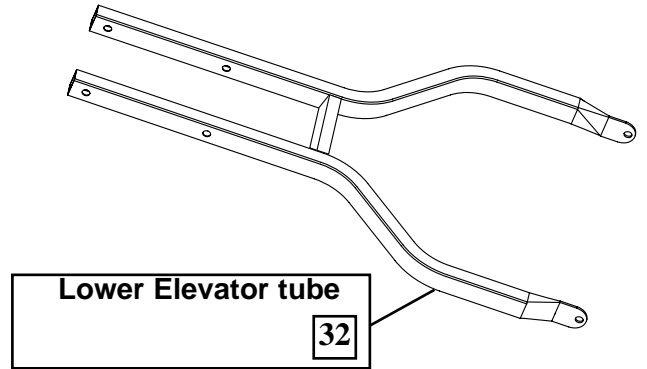
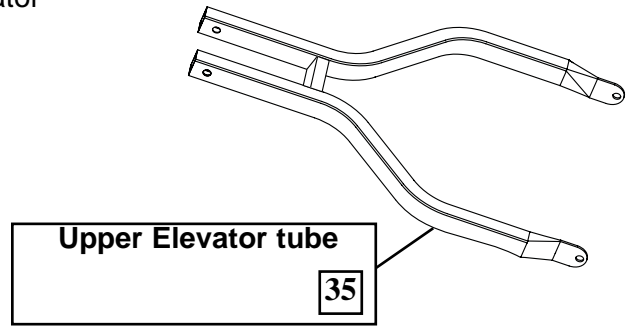
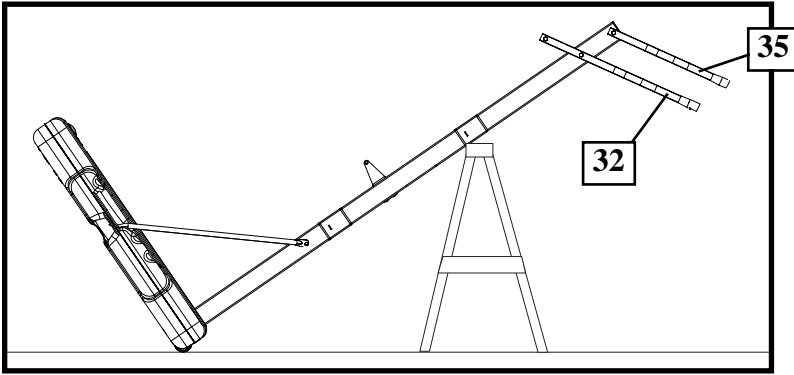

**WARNING!**

TWO CAPABLE ADULTS  
REQUIRED FOR THIS  
PROCEDURE. FAILURE TO  
FOLLOW THIS WARNING COULD  
RESULT IN SERIOUS INJURY  
AND/OR PROPERTY DAMAGE.

- 11.** While the system is securely resting on the sawhorse. Install elevator tubes (32 and 35) to top pole section (4) as shown. Install pole cap (38) at this time.

**COMPLETED ASSEMBLY**

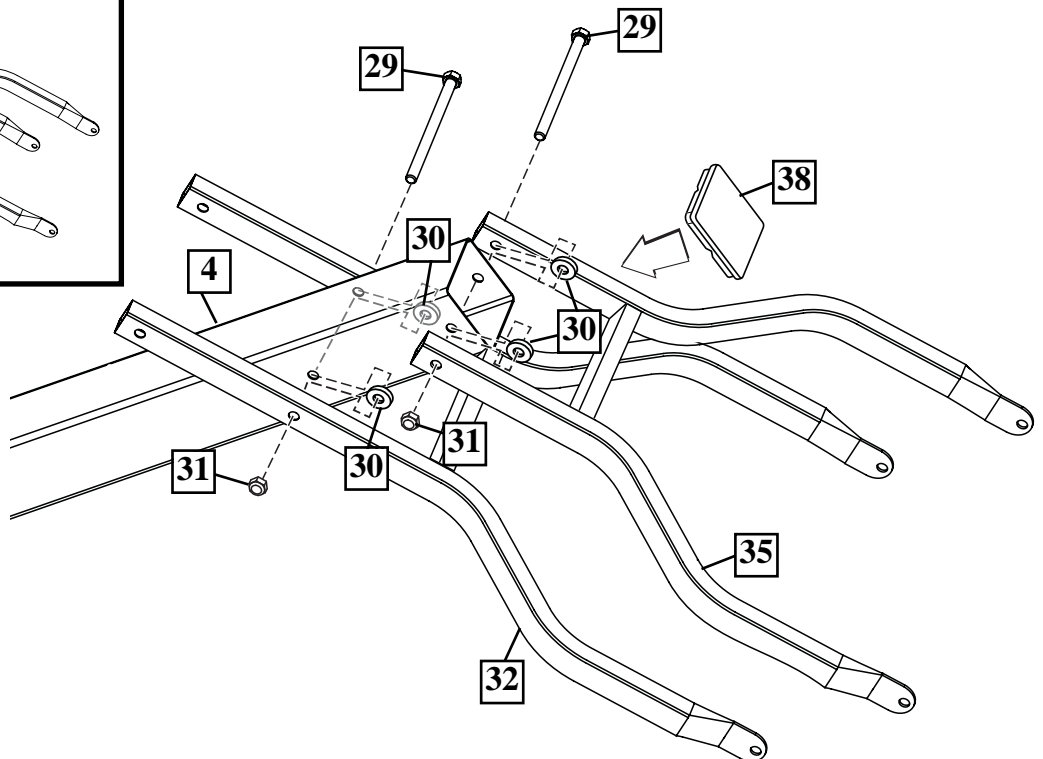
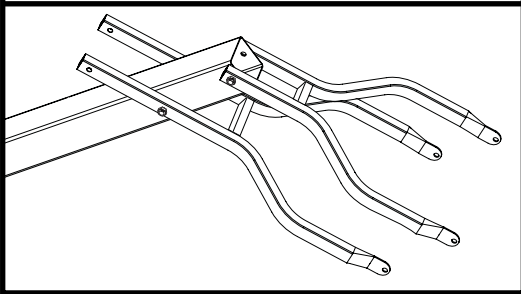

**WARNING!**

TIGHTEN BOLT (29) IN  
LOCK NUT (31) UNTIL  
FLUSH (EVEN) WITH LOCK  
NUT'S OUTER EDGE.

## SECTION B: ATTACH THE BACKBOARD

This is what your system will look like when you've finished this section.

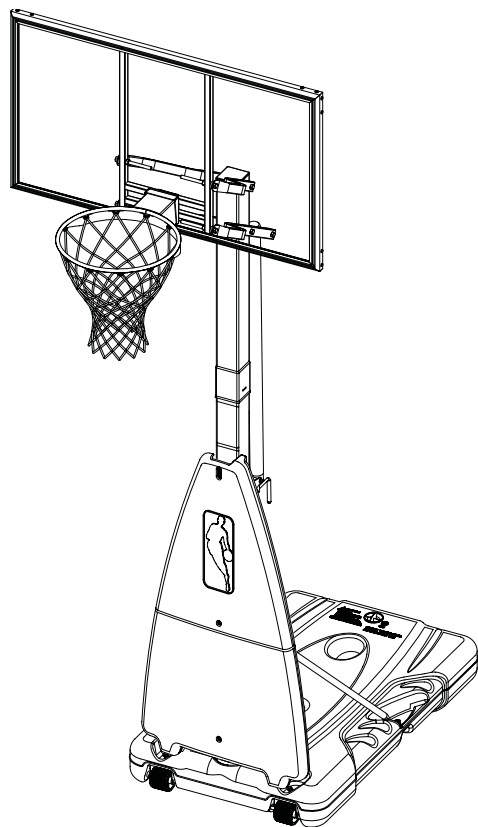

## TOOLS REQUIRED FOR THIS SECTION

(2) Wrenches



1/2" and 3/4"

AND/OR

(2) Socket Wrenches and Sockets

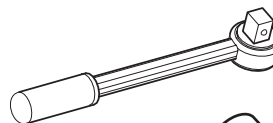

1/2"



3/4"

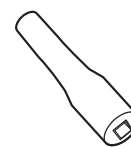

Extension

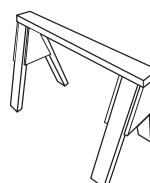

Sawhorse or Support Table

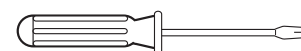

Phillips Screwdriver

1.

While still supported on sawhorse. Attach elevator tubes (32, 35) to backboard using spacers (30), bolts (23), and nuts (31) as shown.

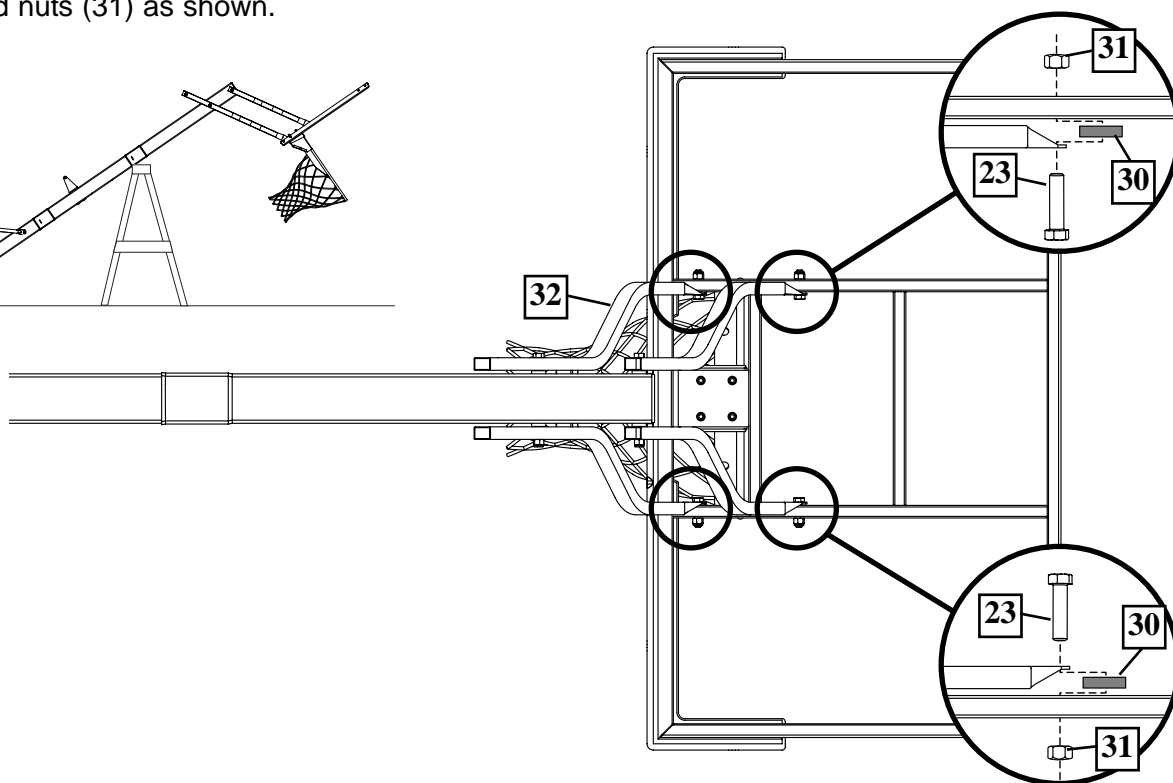
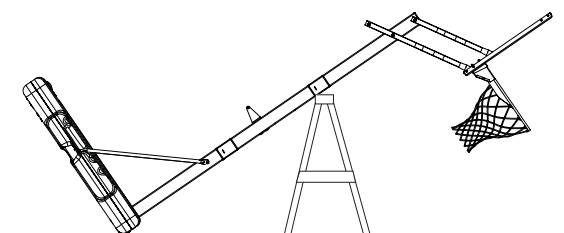

2.

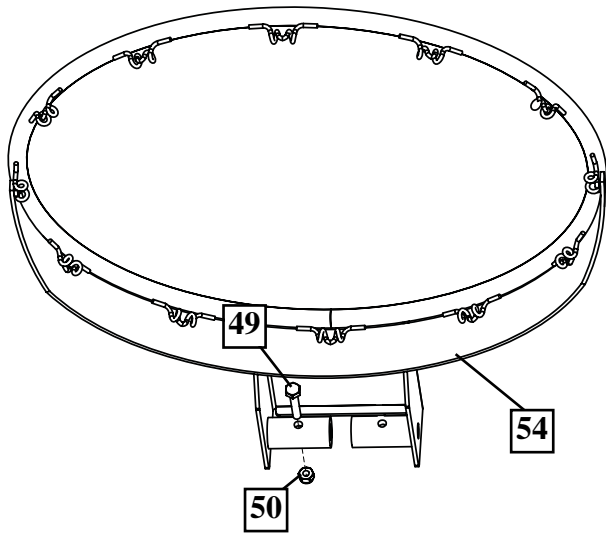

A. Insert bolt (49) into area of rim shown and secure with nut (50).

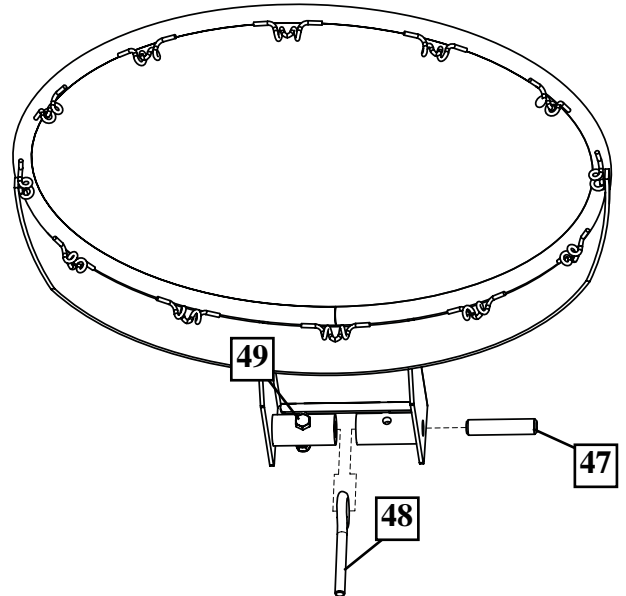

B. Insert spacer (47) into area of rim shown and insert eyebolt (48) so that it is secured in place by the spacer (47).

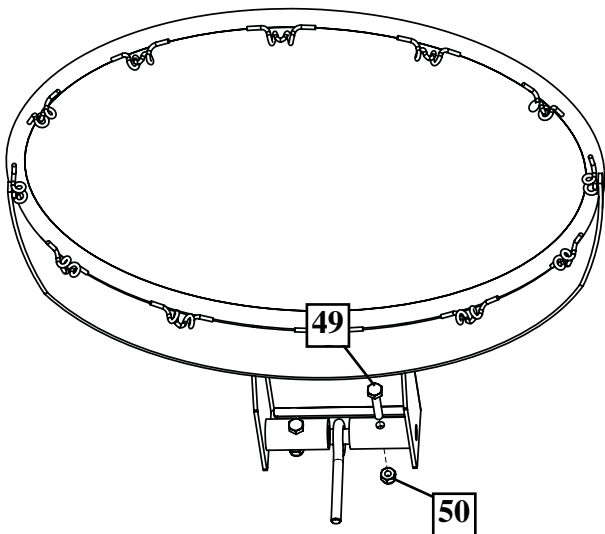

C. Secure spacer in place by inserting bolt (49) and tightening with nut (50).

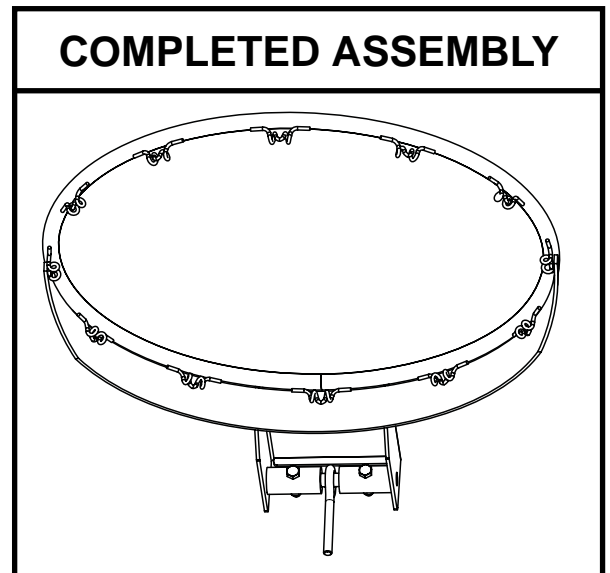

- 3.** Attach board bracket (53) to rim by inserting bolt (55) through washers (57 & 52) and spacer (51). Secure with nut (56). Ensure that eyebolt (48) slips through hole in bracket (53). See completed assembly.

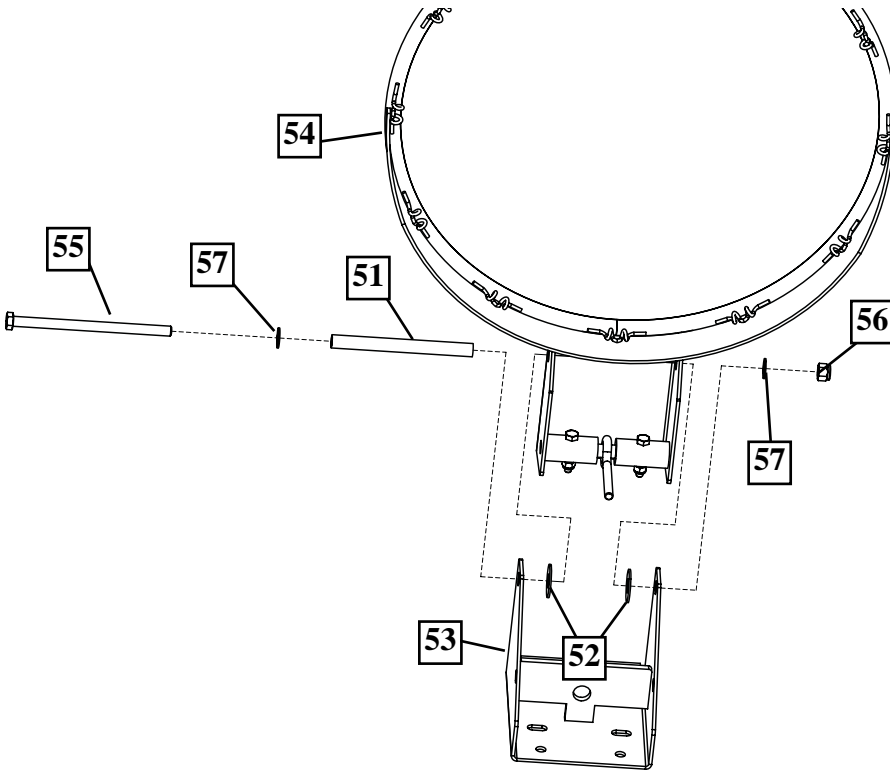

### COMPLETED ASSEMBLY

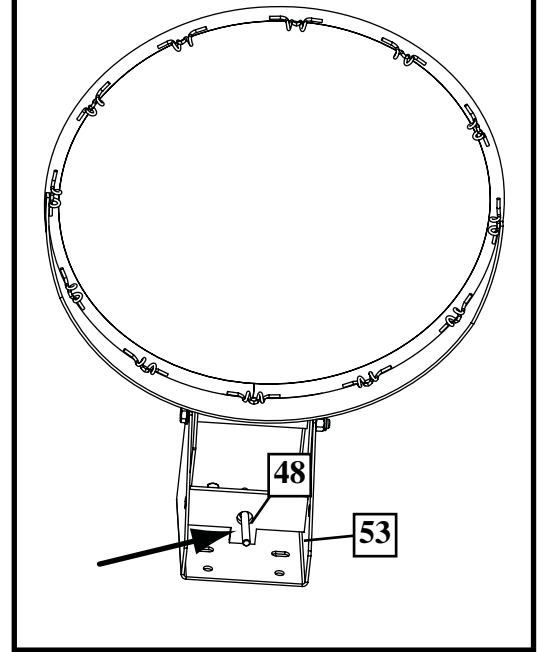

- 4.** Secure spring (58) to eyebolt (48) with washer (59) and skirted nut (60).

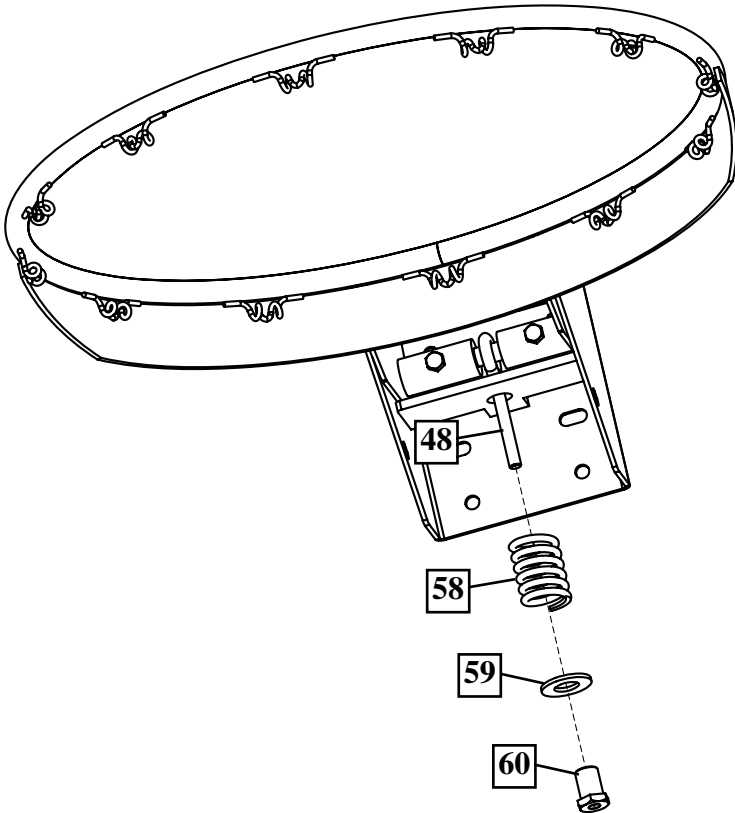

### COMPLETED ASSEMBLY

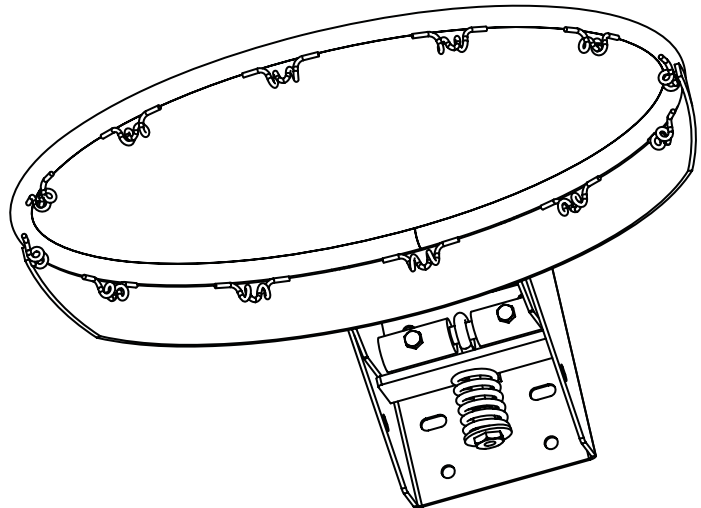

**5.** Attach rim assembly to board using bolts (46) and nuts (14).

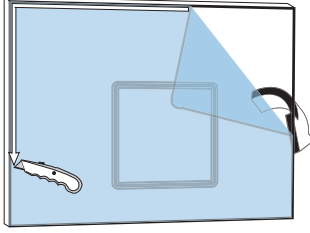
 <b>IMPORTANT!</b>	
<p><b>Carefully cut and peel protective film away from board prior to attaching rim.</b></p>	

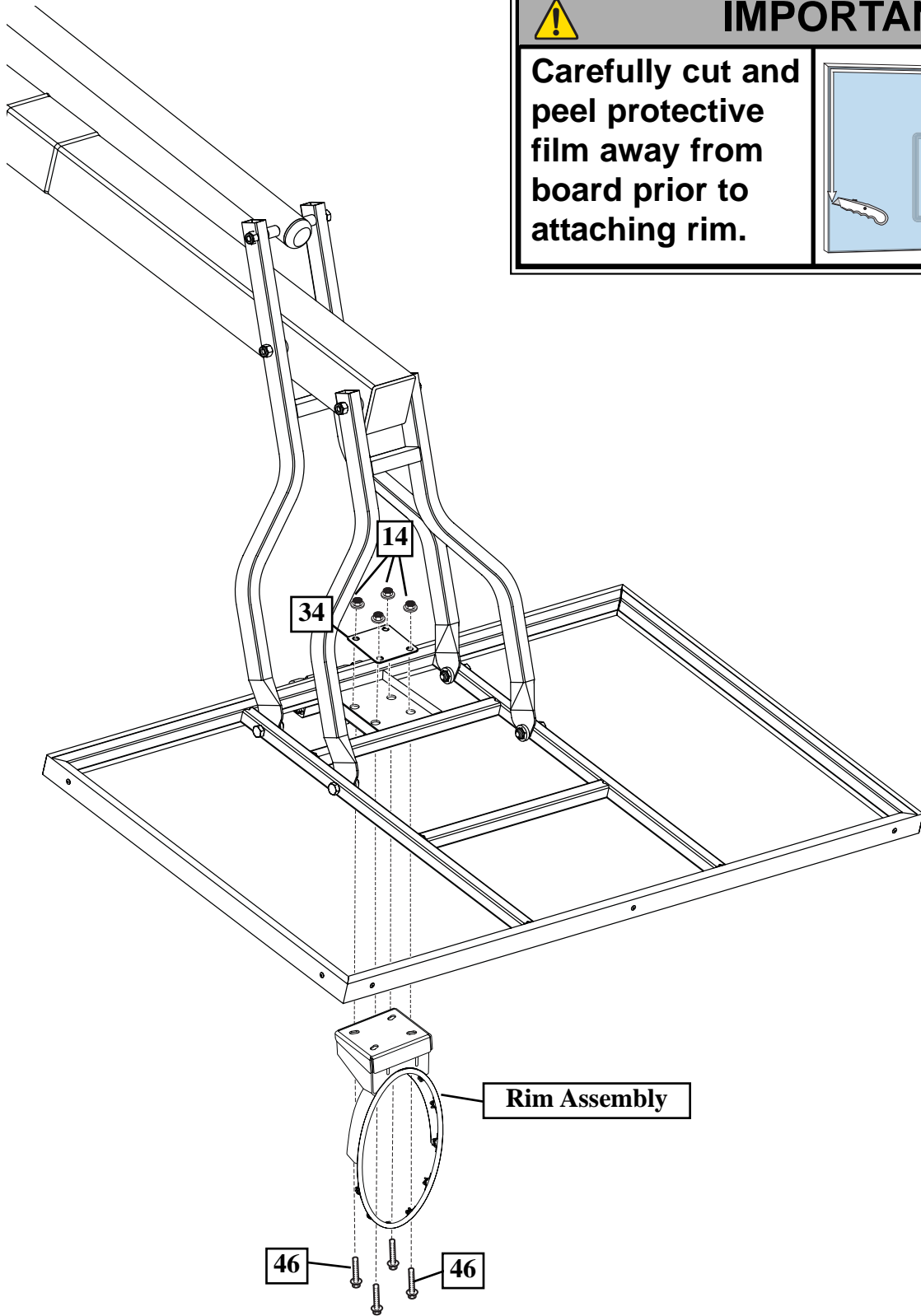

**6.** Install handle assembly (3, 17 and 11) to lower elevator tubes (32) using bolt (29), spacers (36), and nut (31) as shown.

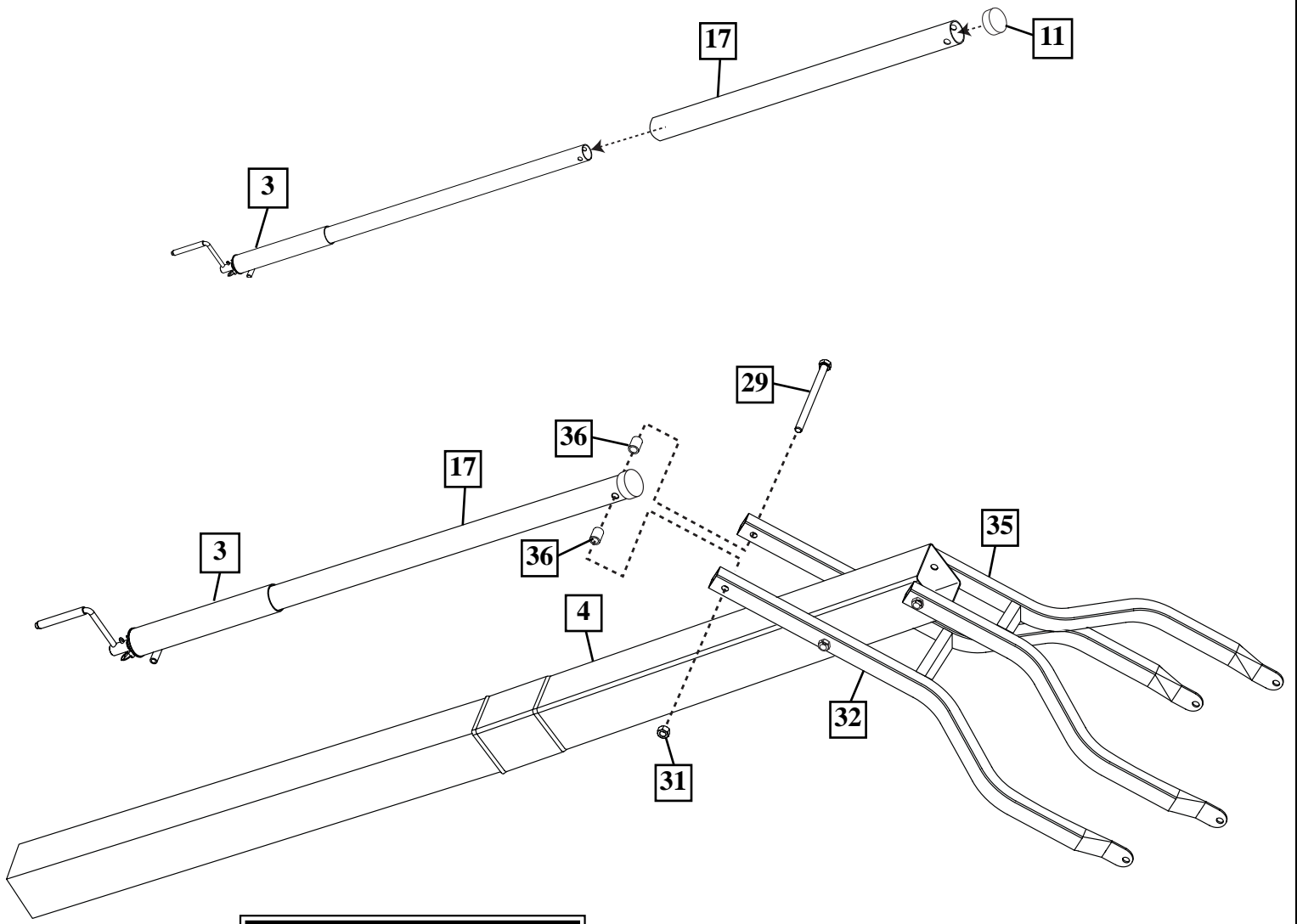

**! WARNING!**

TIGHTEN BOLT (29) IN LOCK NUT (31) UNTIL FLUSH (EVEN) WITH LOCK NUT'S OUTER EDGE.

**7.** Secure the handle assembly (3, 17 and 11) to pole bracket (15) using bolt (20) and nut (10) as shown.

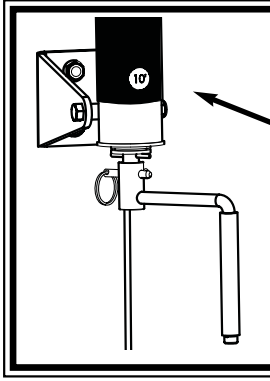
	<p><b>NOTE:</b></p> <p>Before going on to next step, set adjustable system assembly to the 10' (3.05 m) setting.</p>
-----------------------------------------------------------------------------------	----------------------------------------------------------------------------------------------------------------------

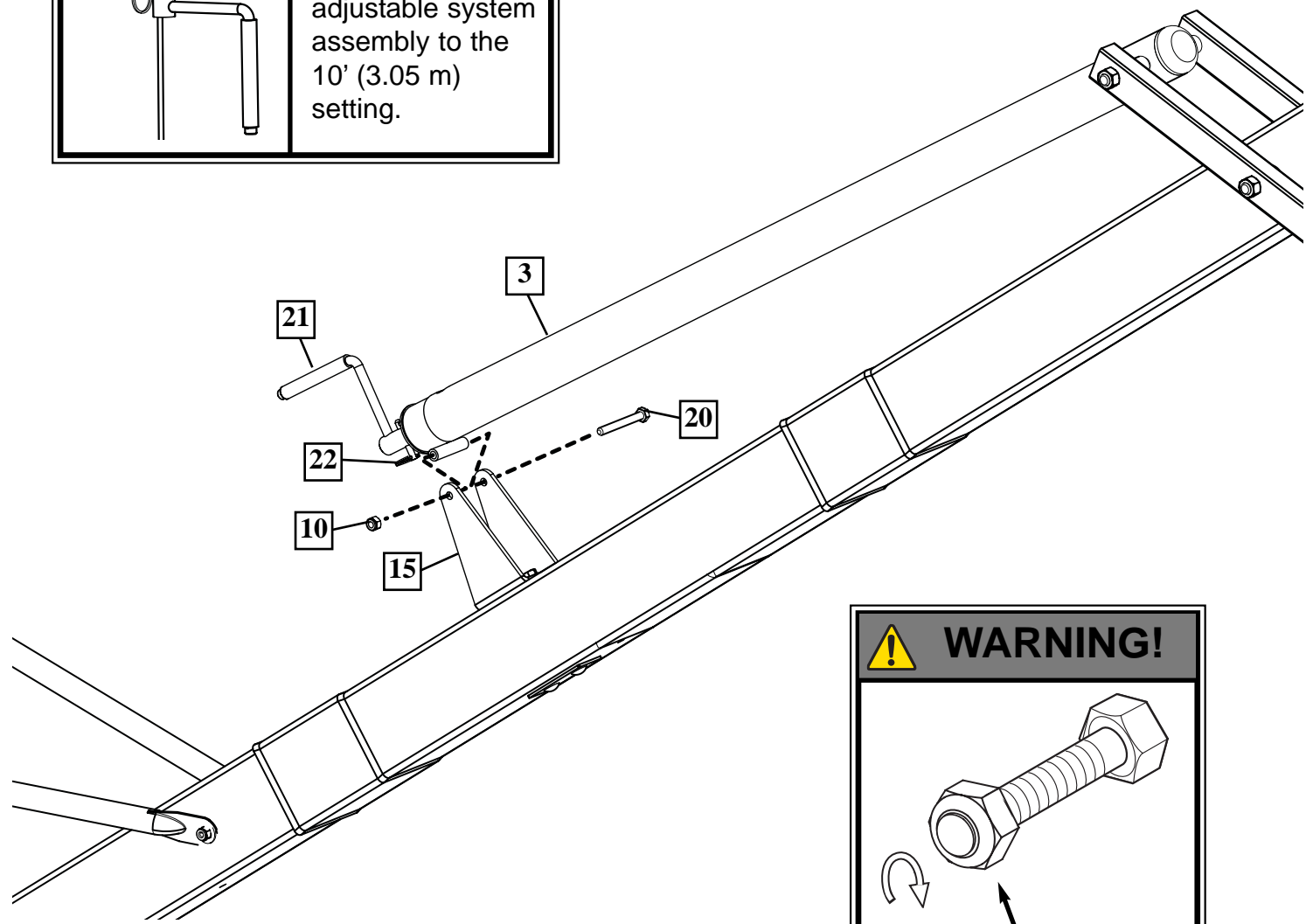

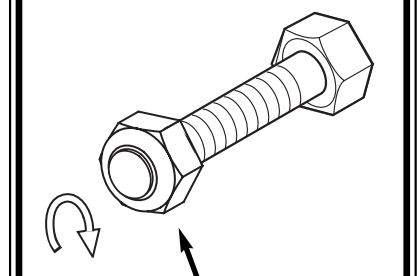
<p><b>! WARNING!</b></p>

<p>TIGHTEN BOLT (20) IN LOCK NUT (10) UNTIL FLUSH (EVEN) WITH LOCK NUT'S OUTER EDGE.</p>

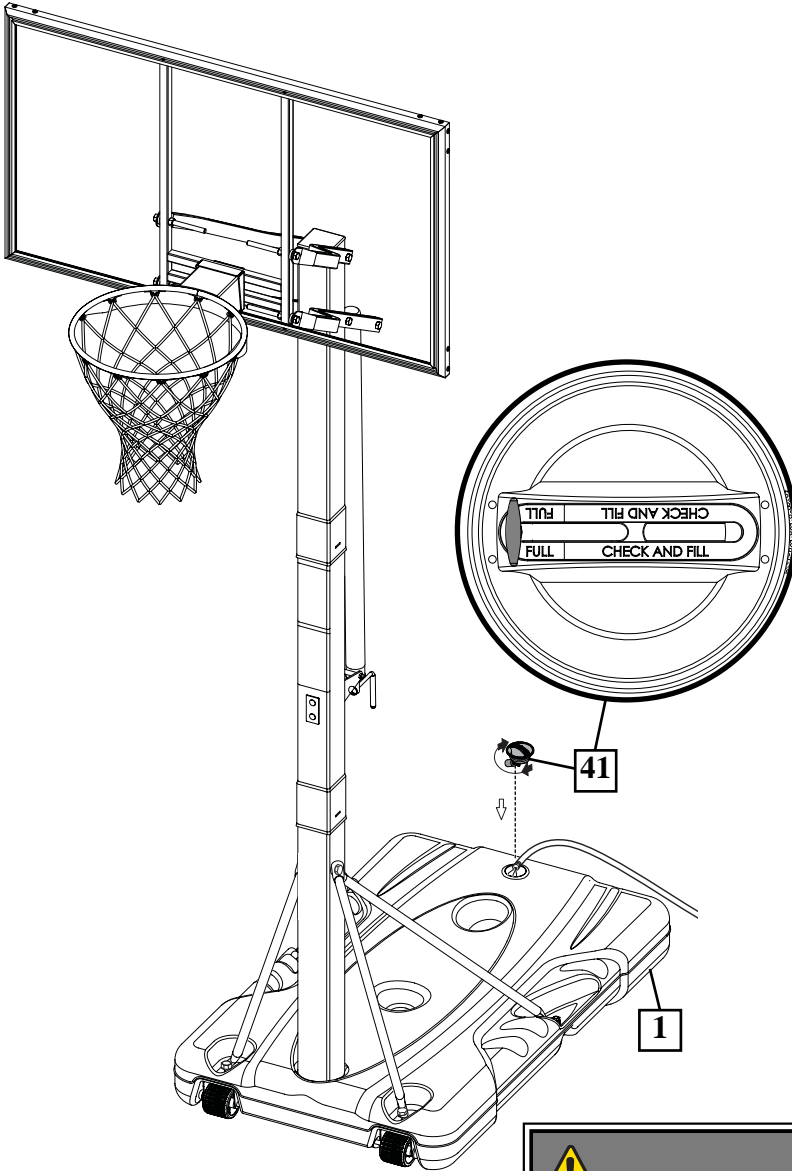
- 8.** Roll completed assembly to desired position. Fill tank with water (approx. 40 gallons (128 Liters)) or sand (approx. 475 lbs. (216 kg)) and rotate the cap (41) into base (1).



<b>WARNING!</b>	
	<b>TWO CAPABLE ADULTS REQUIRED FOR THIS PROCEDURE. FAILURE TO FOLLOW THIS WARNING COULD RESULT IN SERIOUS INJURY AND/OR PROPERTY DAMAGE.</b>
	<b>DO NOT LEAVE ASSEMBLY UNATTENDED WHEN EMPTY; IT MAY TIP OVER.</b>
<b>CAUTION!</b>	
	<b>ADD TWO GALLONS (7.6 LITERS) OF NON-TOXIC ANTIFREEZE IN SUB-FREEZING CLIMATES.</b>
	<b><i>IF USING SAND:</i> 2 GALLONS OF ANTI-FREEZE IS <u>NOT</u> REQUIRED.</b>

<b>WARNING!</b>	
	<b>Cap (41) MUST be tightened COMPLETELY and SECURELY to prevent leakage. CHECK WATER LEVEL BEFORE EACH USE! FAILURE TO FOLLOW THIS WARNING COULD RESULT IN SERIOUS INJURY AND/OR PROPERTY DAMAGE.</b>

**9.** Attach stadium pad (37) to pole using Bolts (16), nuts (14), and vinyl covers (44).

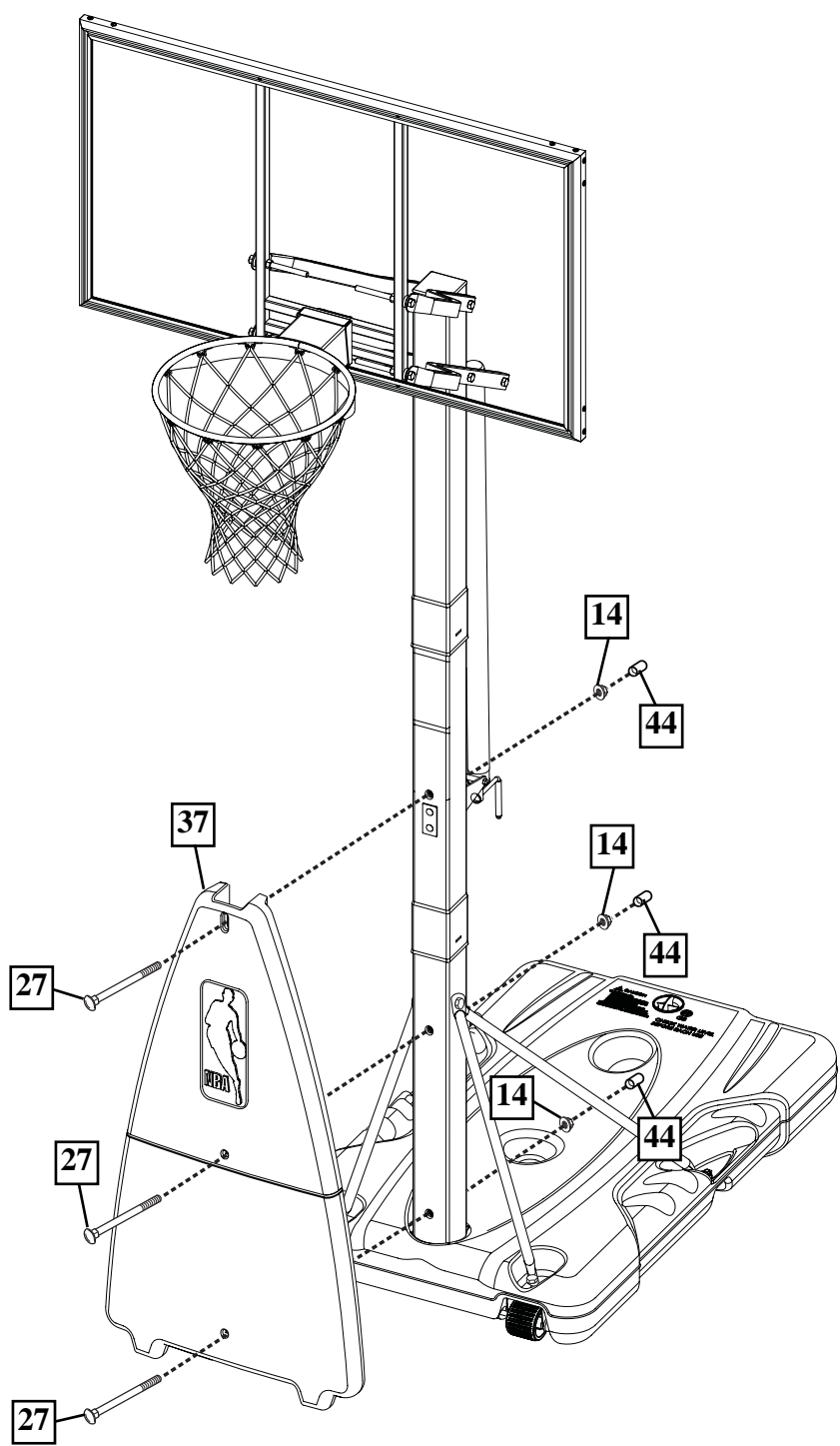

**10.** Install net (43).

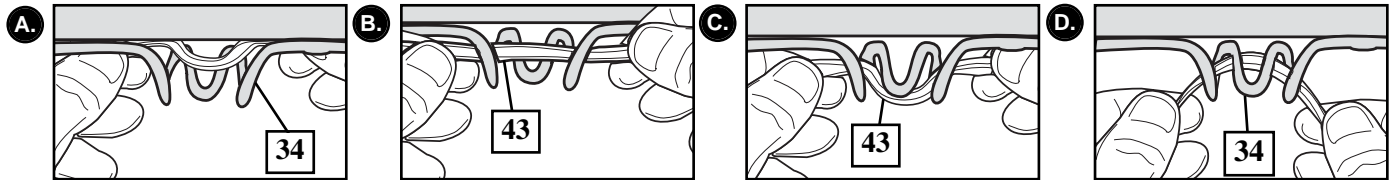

**11.** Apply Height Adjustment and Moving Label (33) to front of pole, where it is clearly visible.

<b>CAUTION!</b>	
	<p><b>DO NOT OVER-CRANK HANDLE BEYOND THE MANUFACTURED HEIGHT-INDICATOR RANGE OF 7-1/2 - 10 FEET. DAMAGE MAY BE CAUSED TO THE SCREW JACK'S INTERNAL ADJUSTMENT MECHANISM IF ADJUSTED OVER 10 OR UNDER 7-1/2 FEET.</b></p>
	<p><b>HEIGHT AND MOVING LABEL MUST NOT OBSTRUCT FACTORY ATTACHED WARNING LABEL.</b></p>

**HEIGHT ADJUSTMENT**

Rotate crank handle to raise and lower backboard.

Do not over crank handle beyond the manufactured height indicator range of 7-1/2 - 10 feet. Damage may be caused to the screw jack's internal adjustment mechanism if adjusted over 10 or under 7-1/2 feet.

**MOVING SYSTEM**

1. While holding pole, rotate basketball system forward until wheels engage with ground.
2. Move basketball system to desired location.
3. Carefully rotate basketball system upright.
4. Check system for stability.

33

568090 11/06

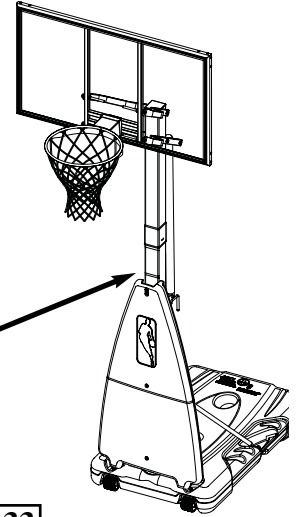

**NOTE:**

Handle (21) can be removed and stored by removing pin (22).

**RIM COVER ATTACHMENT**

**12.**

**NOTE:**

Cover plate (28) will fit INSIDE back bracket.

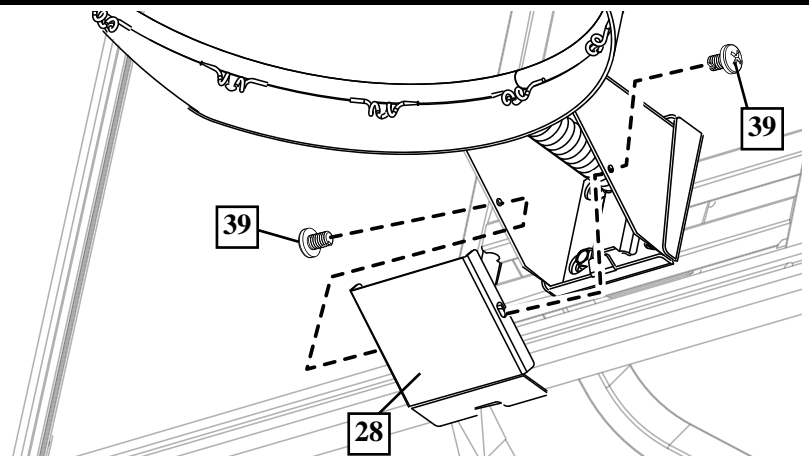

# SECTION C: BOARD PAD

## ITEMS REQUIRED FOR THIS SECTION

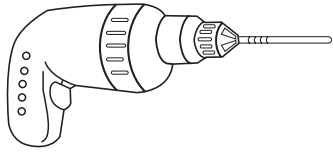

Portable Drill with Torque Adjustment



Socket Wrenches and Sockets



5/16"

## PARTS LIST - See Hardware Identifier

<input checked="" type="checkbox"/> <u>Item</u>	<u>Qty.</u>	<u>Part No.</u>	<u>Description</u>
<input type="checkbox"/> 1	1	600063	Board Pad, Left Section
<input type="checkbox"/> 2	1	600064	Board Pad, Right Section
<input type="checkbox"/> 3	1	600082	Board Pad, Center Section
<input type="checkbox"/> 4	8*	201538	Screw, Self Drilling
<input type="checkbox"/> 5	8*	202219	Cap, Screw
<input type="checkbox"/> 6	1	205355	Drill Bit, 11/64

## HARDWARE IDENTIFIER

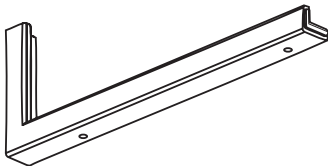

#1 (1)

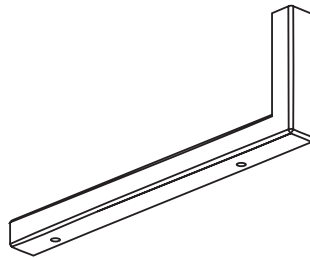

#2 (1)

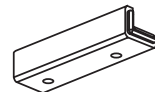

#3 (1)

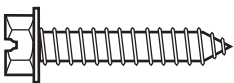

#4 (8)\*



#5 (8)\*



#6 (1)

## BOARD PAD - INSTALLATION

The enclosed Molded Edge Guards interlock together to form bottom and side protection for one backboard with an overall width of 54".

**1.** Check the fit of the edge guards and reposition slightly if necessary. It may be necessary to trim away some material to fit it around the goal or supports. **NOTE: CHECK FASTENER LOCATIONS TO MAKE SURE THEY WILL NOT DAMAGE THE BACKBOARD GLASS.**

**2.** Using a 5/16 socket wrench or portable drill with a 5/16 socket attachment with the torque adjustment at the lowest setting, fasten the edge guards in place with the provided self-drilling, self-tapping screws (4). **NOTE: DO NOT OVER TIGHTEN SCREWS, IT MAY STRIP OUT THE SCREWS.**

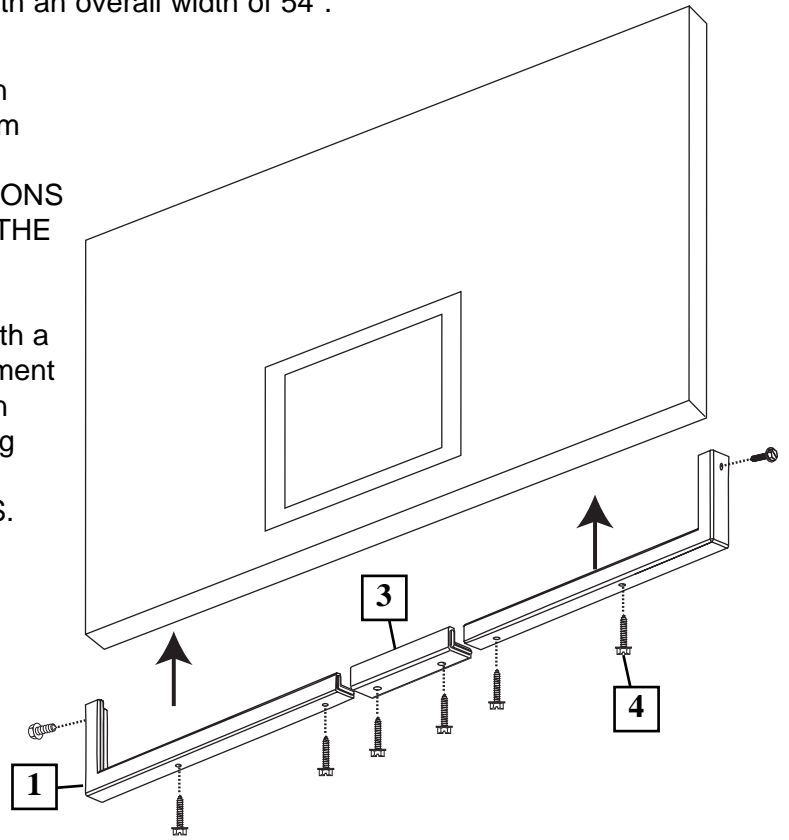

**3.** Using a portable drill (with adjustable torque) and a 5/16 socket and extension drill through the backboard frame and secure the pads in place with self-tapping screws provided (4).

It may be necessary to use an 11/64 drill bit (6) to pre-drill on some backboards (FIG. A).

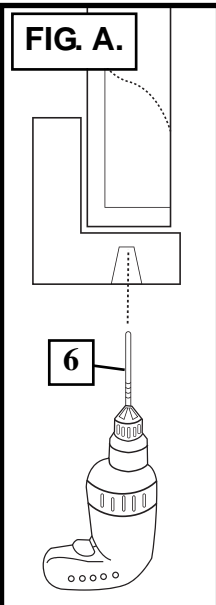

A center punch is recommended to mark hole locations prior to drilling to keep drill bit from wandering.

If the ends of the screws are exposed after installation, place the screw protectors (5) over the ends to prevent injury.

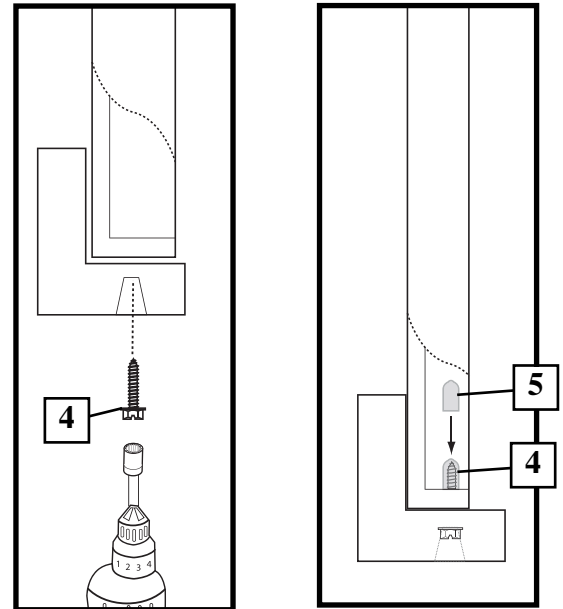

**4.** Collect any metal shavings that may have fallen onto the floor or driveway to prevent injury.